

**Singularities of bihamiltonian
systems and the
multidimensional rigid body**

by

Anton Izosimov

A Doctoral Thesis

Submitted in partial fulfilment of the requirements for the
award of Doctor of Philosophy of Loughborough University

24th January 2012

© A Izosimov 2012

Abstract.

Two Poisson brackets are called compatible if any linear combination of these brackets is a Poisson bracket again. The set of non-zero linear combinations of two compatible Poisson brackets is called a Poisson pencil. A system is called bihamiltonian (with respect to a given pencil) if it is hamiltonian with respect to any bracket of the pencil. The property of being bihamiltonian is closely related to integrability. On the one hand, many integrable systems known from physics and geometry possess a bihamiltonian structure. On the other hand, if we have a bihamiltonian system, then the Casimir functions of the brackets of the pencil are commuting integrals of the system. We consider the situation when these integrals are enough for complete integrability. As it was shown by Bolsinov and Oshemkov, many properties of the system in this case can be deduced from the properties of the Poisson pencil itself, without explicit analysis of the integrals. Developing these ideas, we introduce a notion of linearization of a Poisson pencil. In terms of linearization, we give a criterion for non-degeneracy of a singular point and describe its type.

These results are applied to solve the stability problem for a free multidimensional rigid body.

Keywords.

Bihamiltonian systems, integrable systems, singularities, multidimensional rigid body

Acknowledgements.

I would like to express many thanks to my supervisor Professor Alexey Bolsinov for pointing out the problem, fruitful discussions and useful comments. Thanks to all the staff of the School of Mathematics at Loughborough University for the discussion-friendly and encouraging environment, constant seminar and conference activity, and useful and effective administrative support.

I also would like to thank the Overseas Research Students Awards Scheme and the School of Mathematics of Loughborough University for the financial support during my PhD studies.

I am also grateful to the government of the Russian Federation for the limited financial support (under the agreement 11.G34.31.0054).

Contents

1	Introduction	1
1.1	Statement of the problem	1
1.2	Structure of the thesis	5
1.3	Integrability and non-degeneracy	7
1.4	Jordan-Kronecker theorem	10
1.5	Bihamiltonian systems and integrals in involution	12
1.6	Completeness	14
2	Definitions and the non-degeneracy criteria	15
2.1	Linear pencils	15
2.2	Singularities associated with integrable linear pencils	18
2.3	Linearization of a Poisson pencil	24
2.4	The non-degeneracy criterion	26
3	Zero order theory	30
3.1	Geometry of a pair of skew-symmetric forms on a vector space	30
3.2	The recursion operator	36
4	First order theory	39
4.1	Definition of the operator $D_f P$	39
4.2	Operators $D_f P_\alpha$ for $f \in \mathcal{F}$	42

4.3	Operator $D_f P$ and linearizations of hamiltonian vector fields	46
5	Proof of the main theorems	49
5.1	Non-degeneracy of linear pencils	49
5.2	Classification of non-degenerate linear pencils: the complex case	51
5.3	Classification of non-degenerate linear pencils: the real case	56
5.4	Proof of the second part of Theorem 6	59
5.5	Proof of the non-degeneracy criterion for arbitrary pencils	60
6	Multidimensional rigid body	64
6.1	Introduction	64
6.2	The equations	69
6.3	Description of relative equilibria	70
6.4	Parabolic diagram of a regular relative equilibrium	73
6.5	Stability theorems	75
6.6	The bihamiltonian structure	82
6.7	Notations	85
6.8	The bad set	86
6.9	Complete integrability	87
6.10	Rank zero singular points	88
6.11	Non-degeneracy and type theorems	91
6.12	Non-degeneracy: scheme of the proof	92
6.13	Description of $\Lambda(M)$	92
6.14	When is the pencil diagonalizable?	96
6.15	Linearization	97
6.16	Proof of non-degeneracy and type theorems	103
6.17	Non-resonancy	105
6.18	Proof of stability theorems	110

Chapter 1

Introduction

1.1 Statement of the problem

A system is called bihamiltonian if it is hamiltonian with respect to a whole one-dimensional family of Poisson brackets (“Poisson pencil”). It is well known that bihamiltonian systems are often completely integrable. The relation between bihamiltonian structure and integrability was first noted by F. Magri in his paper [25], where the infinite-dimensional situation was studied. The observation made by Magri is the following: if a (partial differential) equation admits two Hamiltonian representations, then we can construct an infinite sequence of commuting integrals.

The finite-dimensional situation was probably first considered by Gelfand and Dorfman in [17].

Theorem 1 (Gelfand-Dorfman, [17]). *Let A, B be two non-degenerate compatible Poisson structures and v be a vector field hamiltonian with respect to both of them, i.e.*

$$v = Adf_1 = Bdf_0$$

for some functions f_0, f_1 . Then, provided that the first cohomology group of

the manifold vanishes, it is possible to find functions f_2, f_3, \dots such that

$$\text{Ad}f_{i+1} = Bdf_i$$

and all f_i are integrals of v , which are in involution with respect to both A and B .

Therefore, if a vector field is bihamiltonian with respect to two compatible non-degenerate brackets, we can find many integrals in involution. Usually, these integrals are enough for complete integrability.

Another idea for constructing integrals of a bihamiltonian system is brought by the following

Theorem 2 (Magri-Morosi, [26]). *Let v be a vector field hamiltonian with respect to two non-degenerate Poisson structures A and B . Let $R = A^{-1}B$. Then*

- *Traces of powers of R are integrals of v . They are in involution with respect to both A and B .*
- *If the multiplicities of all the eigenvalues of R are equal to two, then v is Liouville integrable.*

The situation we are going to discuss is different: let the brackets forming a pencil be degenerate. In this case another idea can be applied: if v is bihamiltonian with respect to a pencil, then all Casimir functions of all maximal rank brackets of the pencil are integrals of v in involution. To author's knowledge, this was first noted by Reiman and Semenov-Tyan-Shanskii in [36]. However, this construction can be also considered as a generalisation of the argument shift method, introduced by A.S.Mischenko and A.T.Fomenko in [30], and the Manakov construction of the integrals in the Euler case of multidimensional rigid body dynamics (see [27] and Chapter 6 of this thesis).

It often happens that the integrals obtained from the Casimir functions of the brackets of the pencil are enough for complete integrability of the system. The necessary and sufficient condition for this was obtained by A.V.Bolsinov in [5].

On the other hand, many integrable systems appearing in geometry, mechanics and physics possess a bihamiltonian structure (see, for example, [6, 13]). In spite of the fact that the complete integrability of these systems was proved *before* the bihamiltonian structure was found, the bihamiltonian representation is useful for the qualitative analysis of the dynamics, as it was shown by A.V.Bolsinov and A.A.Oshemkov in [8].

The theory of qualitative (or topological) analysis of integrable hamiltonian systems is due to the works of A.T.Fomenko and his school (see [15, 16, 7]), as well as L.M.Lerman and Ya.L.Umanskiy (see [20, 21, 22, 23, 24]), and M.P.Kharlamov (see [18]). The idea of this theory goes back to the Arnold-Liouville theorem (see [2, 7]), which says that the phase space of an integrable hamiltonian system is foliated almost everywhere into invariant tori, and the dynamics on these tori is quasi-periodic. Consequently, if one aims to understand the dynamics of an integrable hamiltonian system, it is very important to study the topology of the foliation into tori (so-called Liouville foliation). The second idea, successfully applied by the mentioned authors, can be formulated as follows: *the topology of a Liouville foliation is mainly defined by the singularities of the system.* Therefore, the theory of qualitative analysis of integrable hamiltonian systems is mainly the theory of singularities of such systems.

Singular points of an integrable systems are those points in which the integrals become dependent. According to the general scheme of the theory of integrable hamiltonian systems, the first thing we should do to describe the

behavior of the system is to find the singular points. In order to do this, one should calculate the Jacobi matrix for the set of integrals and find the points at which the rank of this matrix drops, which can be very complicated in large dimensions. However, if the system possesses a bihamiltonian structure, this reduces to a procedure of describing the singular points of the pencil, i.e. the union of singular points of all brackets of the pencil, which is much easier in examples than the calculations with the Jacobi matrix (A.V.Bolsinov, [5]).

As it was shown by A.V.Bolsinov and A.A.Oshemkov in [8], bihamiltonian structure also allows us to simplify the analysis of topology of Liouville foliation in the neighbourhood of a singular point. In particular, bihamiltonian structure allows us to prove non-degeneracy of singular points.

Non-degenerate singular points are, in some sense, generic singular points. The notion of non-degenerate singular point of an integrable system is analogous to the notion of Morse singular point of a smooth function. Instead of the Morse lemma we have the Eliasson theorem here: the Liouville foliation in the neighbourhood of a singular point is symplectomorphic to the foliation given by the quadratic parts of the integrals. The complete invariant of the Liouville foliation in the neighbourhood of a non-degenerate singular point is the (Williamson) *type* of the point - three non-negative integers k_e, k_h, k_f such that

$$k_e + k_h + 2k_f + r = n,$$

where r is the rank of a point and n is the number of degrees of freedom. The notion of type of a singular point of an integrable system is analogous to the notion of an index of a Morse singular point¹.

Thus knowing the type of a singular point makes it possible to describe

¹See Section 1.3 for precise definitions of non-degeneracy and type.

the Liouville foliation as well as dynamics in the neighbourhood of a point². Therefore, the first thing one should do after describing the set of singular points is to check whether these points are non-degenerate and find their type. For an arbitrary system this involves some non-trivial calculations. To solve the problem for bihamiltonian systems, we introduce the notion of linearization of a Poisson pencil at a singular point, which is again a Poisson pencil, but a linear one. The problem of non-degeneracy and type for an initial pencil is reduced to the same problem for a linearized one, while the linear problem can be easily solved in algebraic terms.

We emphasise that while integrable systems are considered to be the most “symmetric” among all dynamical systems, the systems possessing a bihamiltonian structure are even more “symmetric”. Therefore, applying general methods of the theory of integrable systems to bihamiltonian systems seems to be unreasonable, and a separate theory should be developed. An attempt to develop such a theory is made in this thesis.

1.2 Structure of the thesis

In Section 1.3 we give the definition of a complete family of integrals and an integrable hamiltonian system. Further we give definitions of non-degeneracy and type and formulate the Eliasson theorem about the linearization of a Liouville foliation in a neighbourhood of a singular point.

²For example, knowing the type of a point, we can study its Lyapunov stability. Suppose we have a non-degenerate singular point, which is a fixed point of our system. Then, provided the system is non-resonant, this point is stable if and only if it has rank zero and it has a so-called elliptic type, which means that $k_h = k_f = 0$. The same is true for periodic trajectories, with the only difference that rank zero should be replaced with rank one.

In Section 1.4 we formulate the Jordan-Kronecker theorem about the normal form of two skew-symmetric bilinear forms. This theorem plays a very important role in the theory of bihamiltonian systems.

In Section 1.5 we discuss the notion of a bihamiltonian system and give the construction of the involutive family of integrals associated with a bihamiltonian structure.

In Section 1.6 we give A.Bolsinov completeness criterion for the system constructed in Section 1.5 and formulate the question about non-degeneracy and type.

In Sections 2.1-2.3 we introduce the notion of a linear pencil and linearization of an arbitrary pencil. The non-degeneracy and type problem is being solved for linear pencils.

Section 2.4 is devoted to the main result of the thesis: the criterion for non-degeneracy for a general bihamiltonian system and the type determination procedure.

Chapters 3 and 4 contain technical statements and constructions, needed for the proofs. Chapter 3 contains those which involve only zero order terms of the brackets (in other words, we consider a pencil of skew-symmetric forms on a vector space), while chapter 4 deals with the first order terms.

Proofs themselves are given in Chapter 5.

In the last Chapter 6 we apply our results to study stability of relative equilibria of a free multidimensional rigid body.

1.3 Integrability and non-degeneracy

Let $\dot{x} = \text{sgrad } H$ be a hamiltonian system on a symplectic manifold (M^{2n}, ω) , where

$$\text{sgrad } H = \omega^{-1}dH.$$

Let \mathcal{F} be a family of pairwise commuting integrals of the system. It will be convenient to assume that \mathcal{F} is a vector space, i.e. is closed under addition and multiplication by numbers. If it is not so, we can always replace \mathcal{F} with the space linearly spanned by \mathcal{F} .

Definition 1.

1. \mathcal{F} is said to be *complete* on M^{2n} if for almost all $x \in M^{2n}$ the space $d\mathcal{F}(x) = \{df(x), f \in \mathcal{F}\}$ is maximal isotropic with respect to the Poisson bracket ω^{-1} , i.e. has dimension n .
2. If additionally the vector fields $\text{sgrad } f, f \in \mathcal{F}$ are complete, the system $\dot{x} = \text{sgrad } H$ is called *completely integrable*. The foliation of M into the connected components of the common level sets $\{\mathcal{F} = \text{const}\}$ is called in this case *the Liouville foliation*.

Remark 1.3.1. This definition coincides with the classical one if it is possible to choose n functions in \mathcal{F} such that their differentials span $d\mathcal{F}$. This cannot always be done globally, but can be done locally, which guarantees that the Liouville theorem still holds for the systems integrable in our sense.

Definition 2. A point x is called *singular* for a given integrable hamiltonian system if $\dim d\mathcal{F}(x) < n$ (i.e. $d\mathcal{F}(x)$ is not maximal isotropic). The number $\text{rank } x = \dim d\mathcal{F}(x)$ is called *the rank* of a singular point x . A fiber of Liouville foliation, which contains at least one singular point, is called singular. All other fibers are called regular.

The Liouville theorem (see [2, 7]) claims that all compact regular fibers of a Liouville foliation are tori, and the dynamics on these tori is conditionally periodic.

Despite the fact that almost all fibers of a Liouville foliation are regular, it is also important to understand the topology and dynamics in the neighbourhood of singular fibers due to the following reasons:

1. Singular fibers correspond to singular regimes of motion. In particular, fixed points of a system always belong to singular fibers.
2. It is mainly singular fibers which define the global topology of a system.

Let us now define what a non-degenerate singular point is.

Suppose that $f \in \mathcal{F}$, $df(x) = 0$. Then we can consider the linearization of the vector field $\text{sgrad } f$ at the point x . Denote it by A_f . Since the flow defined by $\text{sgrad } f$ preserves the symplectic structure, $A_f \in \mathfrak{sp}(T_x M)$.

Now consider the space $W = \{\text{sgrad } f(x), f \in \mathcal{F}\}$. Since the functions in \mathcal{F} are in involution, all operators A_f vanish on W . Consequently, we can consider A_f as operators on W^\perp/W . Since W is isotropic, W^\perp/W carries a natural symplectic structure and $A_f \in \mathfrak{sp}(W^\perp/W)$. Also note that all A_f commute, therefore the set

$$A_{\mathcal{F}} = \{A_f, f \in \mathcal{F}, df(x) = 0\}$$

is a commutative subalgebra in $\mathfrak{sp}(W^\perp/W)$.

Definition 3. A singular point x is called *non-degenerate*, if the subalgebra $A_{\mathcal{F}}$ constructed above is a Cartan subalgebra in $\mathfrak{sp}(W^\perp/W)$.

If A is an element of a Cartan subalgebra \mathfrak{h} in \mathfrak{sp} , then its eigenvalues

have the form

$$\begin{aligned} & \pm \lambda_1 i, \dots, \pm \lambda_{k_e} i, \\ & \pm \nu_1, \dots, \pm \nu_{k_h}, \\ & \pm \mu_1 \pm \xi_1 i, \dots, \pm \mu_{k_f} \pm \xi_{k_f} i. \end{aligned}$$

The triple (k_e, k_h, k_f) is the same for almost all $A \in \mathfrak{h}$. Let us call this triple the (Williamson) *type* of the Cartan subalgebra \mathfrak{h} . All Cartan subalgebras of the same type are conjugate to each other (Williamson, [39]).

Definition 4. The *type* of a singular point x is the type of the Cartan subalgebra $A_{\mathcal{F}} \subset \mathfrak{sp}(W^\perp/W)$ constructed above.

It is easy to see that for every non-degenerate singular point x the following equality holds: $k_e + k_h + 2k_f = n - \text{rank } x$.

Let us now state the Eliasson theorem about the linearization of a Liouville foliation in a neighbourhood of a non-degenerate singular point.

Definition 5.

1. The foliation given by the function $p^2 + q^2$ in a neighbourhood of the origin in $(\mathbb{R}^2, dp \wedge dq)$ is called an *elliptic singularity*.
2. The foliation given by the function pq in a neighbourhood of the origin in $(\mathbb{R}^2, dp \wedge dq)$ is called a *hyperbolic singularity*.
3. The foliation given by the commuting functions $p_1 q_1 + p_2 q_2, p_1 q_2 - q_1 p_2$ in a neighbourhood of the origin in $(\mathbb{R}^4, dp \wedge dq)$ is called a *focus-focus singularity*.

Theorem 3 (Eliasson-Miranda, see [11, 12, 28] for proof, see also [7]). *A Liouville foliation in a neighbourhood of a non-degenerate singular point of*

rank r and type (k_e, k_h, k_f) is locally fiberwise symplectomorphic to a direct product of k_e elliptic, k_h hyperbolic and k_f focus-focus singularities, multiplied by a trivial foliation $\mathbb{R}^r \times \mathbb{R}^r$.

1.4 Jordan-Kronecker theorem

It is well known that two bilinear symmetric forms, one of which is positive definite, can be simultaneously diagonalized. A similar statement holds for skew-symmetric forms:

Theorem 4 (Jordan-Kronecker theorem, see [38]). *Let A, B be two skew-symmetric forms on a complex vector space V . Assume that B is a generic form in the pencil $\alpha A + \beta B$, i.e.*

$$\text{rank } B \geq \text{rank } (\alpha A + \beta B) \text{ for all } \alpha, \beta.$$

Then there is a basis in V such that A, B will have the following block-diagonal form:

$$A = \left(\begin{array}{cccc} 0 & J_{k_1, \lambda_1} & & \\ -J_{k_1, \lambda_1}^T & 0 & & \\ & & \ddots & \\ & & & 0 & J_{k_m, \lambda_m} \\ & & & -J_{k_m, \lambda_m}^T & 0 \\ & & & & & A_K \end{array} \right),$$

$$B = \begin{pmatrix} 0 & -E_{k_1} & & & \\ E_{k_1} & 0 & & & \\ & & \ddots & & \\ & & & 0 & -E_{k_m} \\ & & & E_{k_m} & 0 \\ & & & & & & & & B_K \end{pmatrix},$$

where

- $J_{k,\lambda}$ is a $k \times k$ Jordan block with the eigenvalue λ .
- E_k is the $k \times k$ identity matrix.
- $\text{rank}(A_K + \lambda B_K)$ does not depend on λ .

Remark 1.4.1. If B is not a generic form, one should replace it with a suitable linear combination $\alpha A + \beta B$.

Remark 1.4.2. The theorem also gives a normal form for A_K and B_K , which we do not need.

The following property of the Jordan-Kronecker form is very important:

Proposition 1.4.1.

$$\text{rank}(A + \lambda B) < \max_{\nu} \text{rank}(A + \nu B) \Leftrightarrow \lambda \in \{\lambda_i, 1 \leq i \leq m\}.$$

Note that we will not use the Jordan-Kronecker form in formulations of theorems, because this form can hardly be calculated explicitly in examples. Nevertheless, it will be convenient to use this form for the illustration of some notions we are going to introduce.

Also note that we will not use the Jordan-Kronecker theorem in the proofs, preferring an invariant style.

1.5 Bihamiltonian systems and integrals in involution

Definition 6. Two Poisson brackets P_0, P_∞ (on a smooth manifold M) are called *compatible* if any linear combination of them is a Poisson bracket again. The set of non-zero linear combinations $\Pi = \{\alpha P_0 + \beta P_\infty\}$ (with complex coefficients) is called in this case a *Poisson pencil*.

Since it only makes sense to consider Poisson brackets up to proportionality, we will write Poisson pencils in the form

$$\Pi = \{P_\lambda = P_0 + \lambda P_\infty\}_{\lambda \in \bar{\mathbb{C}}}.$$

Definition 7. *Rank* of a pencil Π at a point x is the number

$$\text{rank } \Pi(x) = \max_{\lambda} \text{rank } P_\lambda(x).$$

Rank of a pencil Π on a manifold M is the number

$$\text{rank } \Pi = \max_x \text{rank } \Pi(x) = \max_{\lambda} \text{rank } P_\lambda = \max_{\lambda, x} \text{rank } P_\lambda(x).$$

Definition 8. A vector field v is called *bihamiltonian* with respect to a pencil Π , if it is hamiltonian with respect to all brackets of the pencil.

Let Π be a Poisson pencil on M and v be a vector field which is bihamiltonian with respect to Π . We want to construct a complete family of commuting integrals for v . The main idea for this is provided by the following well-known statement.

Proposition 1.5.1 (see [36]). *Let $\Pi = \{P_\lambda\}$ be a Poisson pencil. Then*

1. *If f is a Casimir function of P_λ for some λ , then f is an integral of any vector field bihamiltonian with respect to Π .*

2. If f is a Casimir function of P_λ , g is a Casimir function of P_ν , and $\lambda \neq \nu$, then f and g are in involution with respect to all brackets of the pencil.
3. If f and g are Casimir functions of P_λ , and $\text{rank } P_\lambda(x) = \text{rank } \Pi(x)$, then f and g are in involution with respect to all brackets of the pencil at the point x .

Remark 1.5.1. The third statement can be false if $\text{rank } P_\lambda(x) < \text{rank } \Pi(x)$. For example, let P_0 be an arbitrary non-zero Poisson bracket and $P_\infty = 0$. The set of Casimir functions of P_∞ coincides with the set of all smooth functions. Obviously, not all of them are in involution with respect to P_0 .

However, the statement is true if λ is such that $\text{rank } P_\lambda(x) = \text{rank } \Pi$ for almost all x . This can be proved by the continuity argument.

Let

$$Bad = \{x \in M : \text{rank } \Pi(x) < \text{rank } \Pi\}.$$

Further we will only consider $x \notin Bad$. For such x we can find α such that $\text{rank } P_\alpha(x) = \text{rank } \Pi$. Moreover, we can find $\varepsilon > 0$ and a neighbourhood $U(x)$ such that $\text{rank } P_\nu(y) = \text{rank } \Pi$ for $|\nu - \alpha| < \varepsilon, y \in U(x)$, and all local Casimir functions of P_ν where $|\nu - \alpha| < \varepsilon$ are defined in $U(x)$. Consider a family $\mathcal{F} = \mathcal{F}_{\alpha, \varepsilon}$ generated by all these Casimir functions. Proposition 1.5.1 implies the following.

Proposition 1.5.2. \mathcal{F} is a (local) family of integrals in involution for any system bihamiltonian with respect to our pencil.

Remark 1.5.2. The choice of α and ε is not important which means that our results remain true for any choice of α, ε . Moreover, under some additional conditions we will get the same family of integrals for all α, ε . What is

important in this construction, is the fact that \mathcal{F} is generated by the Casimir functions of brackets which are *regular* at the point x (see Example 2.4.1).

1.6 Completeness

Let

$$\Lambda(x) = \{\lambda \in \overline{\mathbb{C}} : \text{rank } P_\lambda(x) < \text{rank } \Pi(x)\}.$$

and

$$S = \{x : \Lambda(x) \neq \emptyset\}.$$

Definition 9. We will say that Π is *micro-Kronecker* (or simply *Kronecker*), if the set S has measure zero. Giving this definition we follow I.Zakharevich [40] and A.Panasyuk [33].

Theorem 5 (A.V.Bolsinov [5], the criterion of completeness of \mathcal{F} on a regular symplectic leaf). *Let $O(\alpha, x)$ be a symplectic leaf of the bracket P_α passing through a point x such that P_α is regular at x . Then $\mathcal{F}|_{O(\alpha, x)}$ is complete at x if and only if $x \notin S$.*

Corollary 1.6.1. *\mathcal{F} is complete on $O(\alpha, x)$ if and only if the set $S \cap O(\alpha, x)$ has measure zero.*

Corollary 1.6.2. *If Π is Kronecker, then \mathcal{F} is complete on almost all regular symplectic leaves.*

The theorem also implies that singular points of $\mathcal{F}|_{O(\alpha, x)}$ are exactly the points where the rank of some bracket P_β drops. A question arises: **How do we check non-degeneracy of these points and determine their type?**

It turns out that the answer can be given in terms of the so-called linearization of the pencil Π , which will be defined later.

Chapter 2

Definitions and the non-degeneracy criteria

2.1 Linear pencils

Definition 10. Let \mathfrak{g} be a Lie algebra and A be a skew-symmetric bilinear form on it. Then A can be considered as a Poisson tensor on the dual space \mathfrak{g}^* . Assume that the corresponding bracket is compatible with the Lie-Poisson bracket. The Poisson pencil $\Pi^{\mathfrak{g},A} = \{P_\lambda^{\mathfrak{g},A}\}$, where

$$P_\lambda^{\mathfrak{g},A}(x)(\xi, \eta) = \langle x, [\xi, \eta] \rangle + \lambda A(\xi, \eta), \text{ for } \xi, \eta \in \mathfrak{g},$$

will be called the *linear pencil* associated with the pair (\mathfrak{g}, A) .

Giving this definition, we are motivated by the fact that linear pencils arise as a linearization of a general Poisson pencil at a singular point (see Section 2.3). Now we shall discuss some properties of linear pencils.

Proposition 2.1.1. *A form A on \mathfrak{g} is compatible with the Lie-Poisson bracket if and only if this form is a 2-cocycle in terms of the Chevalley-*

Eilenberg complex, i.e.

$$dA(\xi, \eta, \zeta) = A([\xi, \eta], \zeta) + A([\eta, \zeta], \xi) + A([\zeta, \xi], \eta) = 0 \quad (2.1)$$

for any $\xi, \eta, \zeta \in \mathfrak{g}$.

The proof is straightforward.

Corollary 2.1.1. *If a form A is compatible with the Lie-Poisson bracket on \mathfrak{g}^* , then $\text{Ker } A$ is a subalgebra in \mathfrak{g} .*

Proof. Let $\xi, \eta \in \text{Ker } A$. Then last two terms in identity (2.1) vanish, therefore so does the first one, which means that $[\xi, \eta] \in \text{Ker } A$, q.e.d. \square

Remark 2.1.1. A definition of the Chevalley-Eilenberg complex can be found in [10].

Example 2.1.1 (Exact forms or “argument shift method”). Let \mathfrak{g} be an arbitrary Lie algebra and $A_a(\xi, \psi) = \langle a, [\xi, \psi] \rangle$, where $a \in \mathfrak{g}^*$. It is easy to see that A_a is compatible with the Lie-Poisson bracket.

The condition $A = A_a$ is equivalent to the fact that $A = da$ in the Chevalley-Eilenberg complex, therefore the compatibility of A_a and the Lie-Poisson bracket simply means that $d^2 = 0$.

The pencils with $A = A_a$ are the ones which one should consider when constructing an integrable system by the argument shift method (see [30]), therefore we will call them pencils of the argument shift type. It also seems reasonable to call such pencils exact.

We want to use linear pencils to construct commuting functions following the general scheme of Section 1.5. In order to be able to do so, we need the following property of *regularity*:

Definition 11. We will say that a cocycle A on \mathfrak{g} is *regular*, if $\text{rank } \Pi^{\mathfrak{g}, A} = \text{rank } A$.

It is easy to see that if $A = A_a$, then $\text{rank } P_\lambda^{\mathfrak{g}, A} = \dim \mathfrak{g} - \text{ind } \mathfrak{g}$ for any $\lambda \neq \infty$, therefore regularity of A means that $\text{rank } A = \dim \mathfrak{g} - \text{ind } \mathfrak{g}$, i.e. it is equivalent to regularity of the element a . To give a criteria for regularity in the general case, we need a (standard) construction of the central extension of \mathfrak{g} , associated with a form A . Let us consider the space $\mathfrak{g}_A = \mathfrak{g} + \mathbb{K}^1$, where $\mathbb{K}^1 = \langle z \rangle$ is a one-dimensional vector space, and define a commutator $[\cdot, \cdot]_A$ on \mathfrak{g}_A by the following rule:

$$[x, y]_A = [x, y] + A(x, y)z, \text{ for any } x, y \in \mathfrak{g} \subset \mathfrak{g}_A,$$

$$[z, \mathfrak{g}_A]_A = 0.$$

It is easy to see that if A is closed, then the commutator $[\cdot, \cdot]_A$ turns \mathfrak{g}_A into a Lie algebra. Also note that $\mathfrak{g} = \mathfrak{g}_A / \langle z \rangle$ and the lift of A to \mathfrak{g}_A is an exact form. This means that every closed 2-form on a Lie algebra becomes exact after a lift to a certain one-dimensional central extension.

Proposition 2.1.2. *A 2-cocycle A on \mathfrak{g} is regular if and only if its lift \tilde{A} to \mathfrak{g}_A is a differential of a regular element.*

Proof. It suffices to show that A is regular if and only if \tilde{A} is regular. Since $\text{rank } \Pi^{\mathfrak{g}_A, \tilde{A}} = \text{rank } \Pi^{\mathfrak{g}, A}$ and $\text{rank } \tilde{A} = \text{rank } A$, our proposition is proved. \square

Proposition 2.1.3. *If A is a regular cocycle on \mathfrak{g} , then $\text{Ker } A$ is abelian.*

Proof. Let \tilde{A} be the lift of A to \mathfrak{g}_A . Since \tilde{A} is exact, $\text{Ker } \tilde{A}$ is abelian. But $\text{Ker } A = \pi(\text{Ker } \tilde{A})$, where π is the natural projection. Therefore, $\text{Ker } A$ is abelian as well. \square

We will see that in good examples $\text{Ker } A$ is not just an abelian subalgebra, but a Cartan subalgebra.

Suppose that A is regular. Then we can apply the construction of Section 1.5 to the pencil $\Pi^{\mathfrak{g}, A}$ in the neighbourhood of the origin (because the origin

does not belong to *Bad* due to regularity of A) and get a family \mathcal{F} which is involutive with respect to all brackets of the pencil. In particular, with respect to the constant bracket A . Consider the symplectic leaf of A passing through the origin. This is simply a linear subspace of \mathfrak{g}^* . The restriction of \mathcal{F} to this symplectic leaf is complete if and only if $\Lambda(x)$ is empty for almost all x belonging to this subspace (see Corollary 1.6.1). This leads us to the following

Definition 12. A pencil $\Pi^{\mathfrak{g},A}$ with regular A will be called *integrable* if the measure of the set $S \cap O$ is zero where

$$S = \{x : \text{there exists } \lambda \text{ such that } \text{rank } P_{\lambda}^{\mathfrak{g},A}(x) < \text{rank } \Pi^{\mathfrak{g},A}\}$$

and O is the symplectic leaf of A passing through the origin.

We see that if a pencil $\Pi^{\mathfrak{g},A}$ is integrable then there is a well-defined integrable system on the symplectic leaf of A passing through the origin.

2.2 Singularities associated with integrable linear pencils

Suppose that a pencil $\Pi^{\mathfrak{g},A}$ is integrable. Then the Casimir functions of the regular brackets of the pencil define an integrable system on a symplectic leaf of A passing through the origin. The origin is a zero-rank singular point for this system. This means that every integrable linear pencil canonically defines a zero-rank singularity (i.e. a germ of an integrable system at a singular point). Denote the singularity associated with $\Pi^{\mathfrak{g},A}$ by $Sing(\Pi^{\mathfrak{g},A})$.

Example 2.2.1 (Argument shift on semisimple Lie algebras). Let \mathfrak{g} be a semisimple Lie algebra with two or four-dimensional coadjoint orbits and

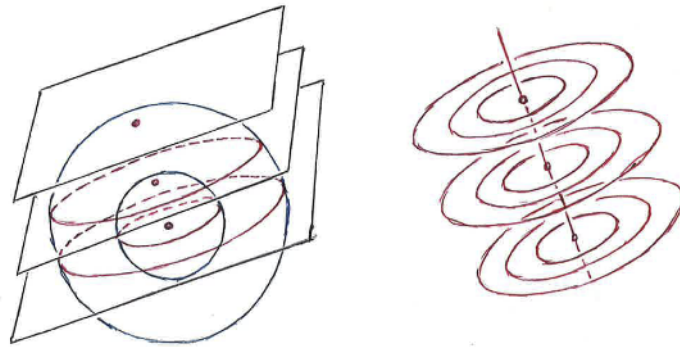

Figure 2.1: Singularity corresponding to $\mathfrak{so}(3)$

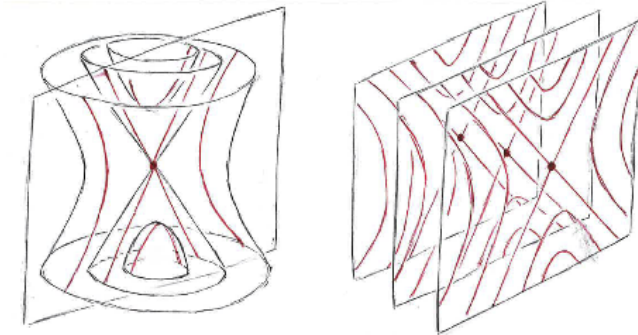

Figure 2.2: Singularity corresponding to $\mathfrak{sl}(2)$, shift by a hyperbolic element

$A = A_a$ be an “argument shift” form, where $a \in \mathfrak{g}^*$ is a regular element.

Below is the list of the corresponding singularities:

1. Two-dimensional orbits: one degree of freedom.
 - $\mathfrak{so}(3)$ - elliptic singularity (center). See Figure 2.1.
 - $\mathfrak{sl}(2)$ - hyperbolic singularity (saddle) if the Killing form is positive on a (Figure 2.2), elliptic if it is negative (Figure 2.3), and degenerate if it is zero (Figure 2.4).
2. Four-dimensional orbits: two degrees of freedom.

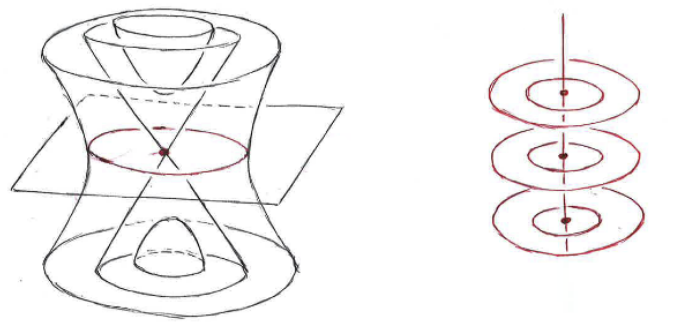

Figure 2.3: Singularity corresponding to $\mathfrak{sl}(2)$, shift by an elliptic element

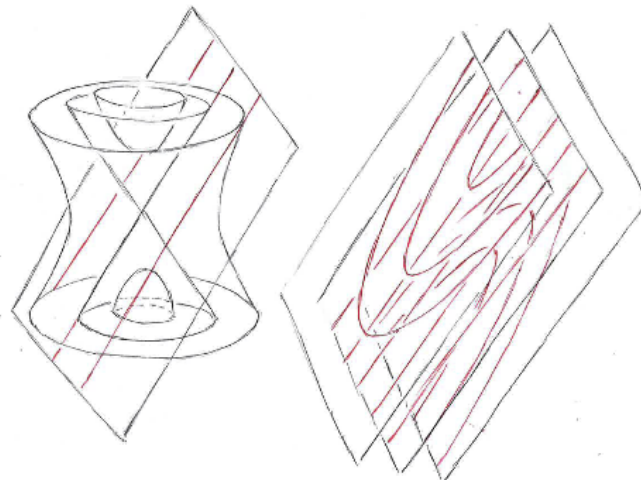

Figure 2.4: Singularity corresponding to $\mathfrak{sl}(2)$, shift by a nilpotent element

- $\mathfrak{so}(4) \simeq \mathfrak{so}(3) \oplus \mathfrak{so}(3)$ - center-center singularity (a product of two elliptic singularities).
- $\mathfrak{so}(2, 2) \simeq \mathfrak{sl}(2) \oplus \mathfrak{sl}(2)$ - saddle-saddle (a product of two hyperbolic singularities), saddle-center (a product of an elliptic and a hyperbolic singularity), center-center (a product of two elliptic singularities) or degenerate singularity (depending on a).
- $\mathfrak{so}(3, 1) \simeq \mathfrak{so}(3, \mathbb{C}) \simeq \mathfrak{sl}(2, \mathbb{C})$ - focus-focus singularity if a is semisimple, degenerate otherwise.

We will see further that no semisimple Lie algebras except for the sums of $\mathfrak{so}(3)$, $\mathfrak{sl}(2)$ and $\mathfrak{so}(3, 1)$ give rise to non-degenerate singularities. The corresponding fact in the theory of integrable systems is the Eliasson theorem: all non-degenerate singularities are products of elliptic, hyperbolic and focus-focus singularities (see Theorem 3).

There are also solvable Lie algebras which give rise to non-degenerate singularities.

Example 2.2.2.

1. Any regular linear pencil on $\mathfrak{e}(2) = \mathfrak{so}(2) \ltimes \mathbb{R}^2$ which is not of the argument shift type gives rise to an elliptic singularity. The argument shift pencil gives rise to a degenerate singularity.
2. Any regular linear pencil on $\mathfrak{e}(1, 1) = \mathfrak{so}(1, 1) \ltimes \mathbb{R}^2$ which is not of the argument shift type gives rise to a hyperbolic singularity. The argument-shift pencil gives rise to a degenerate singularity.
3. Any regular linear pencil on $\mathfrak{e}(2, \mathbb{C}) \simeq \mathfrak{e}(1, 1, \mathbb{C})$ which is not of the argument shift type gives rise to a focus-focus singularity. The argument-shift pencil gives rise to a degenerate singularity.

Definition 13. An integrable linear pencil $\Pi^{\mathfrak{g},A}$ will be called non-degenerate, if the singularity $Sing(\Pi^{\mathfrak{g},A})$ is non-degenerate.

Before giving a classification theorem of non-degenerate pencils, we need to define three special algebras.

Definition 14.

1. Denote by \mathfrak{g}_{\diamond} the Lie algebra generated by e, f, h, t with the following relations:

$$\begin{aligned} [e, f] &= h, \\ [h, \mathfrak{g}_{\diamond}] &= 0, \\ [t, e] &= f, \\ [t, f] &= -e. \end{aligned}$$

This algebra is known as the “diamond Lie algebra” (see [19]).

2. Denote by $\mathfrak{g}_{\diamond}^h$ the Lie algebra generated by e, f, h, t with the following relations:

$$\begin{aligned} [e, f] &= h, \\ [h, \mathfrak{g}_{\diamond}^h] &= 0, \\ [t, e] &= e, \\ [t, f] &= -f. \end{aligned}$$

This algebra may be called the “hyperbolic diamond Lie algebra”.

3. $\mathfrak{g}_{\diamond}^{\mathbb{C}} = \mathbb{C} \otimes \mathfrak{g}_{\diamond} \simeq \mathbb{C} \otimes \mathfrak{g}_{\diamond}^h$ - the common complexification of these two algebras.

Remark 2.2.1. The algebras \mathfrak{g}_\diamond and \mathfrak{g}_\diamond^h are (the only non-trivial) one-dimensional central extensions of $\mathfrak{e}(2)$ and $\mathfrak{e}(1, 1)$.

On the other hand, \mathfrak{g}_\diamond and \mathfrak{g}_\diamond^h may be obtained in the following way: There is a natural action of $\mathfrak{sp}(2)$ on three-dimensional Heisenberg algebra $\mathfrak{h}(3)$. $\mathfrak{sp}(2)$ has subalgebras $\mathfrak{so}(2)$ and $\mathfrak{so}(1, 1)$. The semi-direct sums of $\mathfrak{h}(3)$ with these subalgebras are exactly \mathfrak{g}_\diamond and \mathfrak{g}_\diamond^h .

Definition 15. A complex Lie algebra \mathfrak{g} will be called non-degenerate if it can be represented as

$$\mathfrak{g} \simeq \left(\bigoplus \mathfrak{so}(3, \mathbb{C}) \right) \oplus \left(\left(\bigoplus \mathfrak{g}_\diamond^{\mathbb{C}} \right) / \mathfrak{h}_0 \right) \oplus V,$$

where V is abelian, and \mathfrak{h}_0 is a central ideal.

A real Lie algebra \mathfrak{g} will be called non-degenerate if it can be represented as

$$\begin{aligned} \mathfrak{g} \simeq & \left(\bigoplus \mathfrak{so}(3) \oplus \bigoplus \mathfrak{sl}(2) \oplus \bigoplus \mathfrak{so}(3, \mathbb{C}) \right) \oplus \\ & \oplus \left(\left(\bigoplus \mathfrak{g}_\diamond \oplus \bigoplus \mathfrak{g}_\diamond^h \oplus \bigoplus \mathfrak{g}_\diamond^{\mathbb{C}} \right) / \mathfrak{h}_0 \right) \oplus V, \end{aligned}$$

where V is abelian, and \mathfrak{h}_0 is a central ideal¹.

A type of non-degenerate Lie algebra \mathfrak{g} with respect to its Cartan subalgebra² \mathfrak{h} is the triple (k_e, k_h, k_f) , where

- k_e = is the number of $\mathfrak{so}(3)$ terms in the decomposition of \mathfrak{g} + the number of \mathfrak{g}_\diamond terms + the number of $\mathfrak{sl}(2)$ terms such that the Killing form on $\mathfrak{sl}(2) \cap \mathfrak{h}$ is negative.

¹In other words, a real Lie algebra is non-degenerate if its complexification is non-degenerate.

²By definition, a Cartan subalgebra of an arbitrary Lie algebra is a nilpotent subalgebra which coincides with its normaliser. In the case of non-degenerate algebras Cartan subalgebras are simply maximal diagonalizable abelian subalgebras.

- $k_h =$ is the number of $\mathfrak{g}_{\diamond}^h$ terms + the number of $\mathfrak{sl}(2)$ terms such that the Killing form on $\mathfrak{sl}(2) \cap \mathfrak{h}$ is positive.
- $k_f =$ is the number of $\mathfrak{so}(3, \mathbb{C})$ terms + the number of $\mathfrak{g}_{\diamond}^{\mathbb{C}}$ terms.

Theorem 6 (Classification of non-degenerate linear pencils).

1. A linear pencil $\Pi^{\mathfrak{g}, A}$ is non-degenerate if and only if \mathfrak{g} is non-degenerate and $\text{Ker } A$ is a Cartan subalgebra.
2. Assume that $\Pi^{\mathfrak{g}, A}$ is non-degenerate. Then the type of $\text{Sing}(\Pi^{\mathfrak{g}, A})$ coincides with the type of \mathfrak{g} with respect to $\text{Ker } A$.

The proof of the first statement in the complex case can be found in Section 5.2, and in the real case - in Section 5.3. The proof of the second statement is given in Section 5.4.

Remark 2.2.2. It follows from the theorem that if \mathfrak{g} is non-degenerate and $\text{Ker } A$ is a Cartan subalgebra, then A is automatically regular and the pencil $\Pi^{\mathfrak{g}, A}$ is automatically integrable.

2.3 Linearization of a Poisson pencil

Let P be a Poisson bracket on a manifold M , $x \in M$. It is well-known that the linear part of P defines a Lie algebra structure on the kernel of P at the point x .

The commutator in this algebra is defined as follows: let $\xi, \eta \in \text{Ker } P(x)$. Choose any functions f, g such that $df = \xi, dg = \eta$, and define

$$[\xi, \eta] = d\{f, g\}.$$

The following is well-known (see [10], for example).

Proposition 2.3.1.

1. The commutator $[\cdot, \cdot]$ is well-defined and indeed turns $\text{Ker } P(x)$ into a Lie algebra.
2. If P is regular at the point x , then this algebra is abelian.

Now consider a Poisson pencil $\{P_\lambda = P_0 + \lambda P_\infty\}$ and fix a point x . Denote by $\mathfrak{g}_\lambda(x)$ the Lie algebra on the kernel of P_λ at the point x . For regular λ (i.e. for $\lambda \notin \Lambda(x)$) the algebra \mathfrak{g}_λ is abelian. For singular λ ($\lambda \in \Lambda(x)$) this is not the case in general, therefore $\mathfrak{g}_\lambda(x)$ carries non-trivial information about the behaviour of the pencil in the neighbourhood of x .

Remark 2.3.1. For real λ the algebra $\mathfrak{g}_\lambda(x)$ is real, while for complex λ it is complex.

It turns out that apart from the Lie algebra structure \mathfrak{g}_λ carries one more additional structure.

Proposition 2.3.2. *For any α, β the restrictions of $P_\alpha(x), P_\beta(x)$ on $\mathfrak{g}_\lambda(x)$ coincide up to a multiplicative constant.*

Proof. Since P_λ vanishes on \mathfrak{g}_λ , all other brackets of the pencil are proportional. □

The restriction $P_\alpha|_{\mathfrak{g}_\lambda}$ is a 2-form on \mathfrak{g}_λ . Therefore, it can be interpreted as a constant Poisson bracket on \mathfrak{g}_λ^* .

Theorem 7. *The bracket $P_\alpha|_{\mathfrak{g}_\lambda}$ is compatible with the Lie-Poisson bracket on \mathfrak{g}_λ^* (i.e. $P_\alpha|_{\mathfrak{g}_\lambda}$ is a 2-cocycle on \mathfrak{g}_λ).*

Proof. Since P_α and P_λ are compatible, we have

$$\begin{aligned} & \{\{f, g\}_\alpha, h\}_\lambda + \{\{g, h\}_\alpha, f\}_\lambda + \{\{h, f\}_\alpha, g\}_\lambda + \\ & + \{\{f, g\}_\lambda, h\}_\alpha + \{\{g, h\}_\lambda, f\}_\alpha + \{\{h, f\}_\lambda, g\}_\alpha = 0. \end{aligned}$$

But if $df, dg, dh \in \text{Ker } P_\lambda$ then the first three terms vanish and we can write down

$$\{\{f, g\}_\lambda, h\}_\alpha + \{\{g, h\}_\lambda, f\}_\alpha + \{\{h, f\}_\lambda, g\}_\alpha = 0.$$

or

$$P_\alpha([df, dg], dh) + P_\alpha([dg, dh], df) + P_\alpha([dh, df], dg) = 0,$$

i.e. P_α is a 2-cocycle on \mathfrak{g}_λ , q.e.d. □

Consequently, $P_\alpha|_{\mathfrak{g}_\lambda}$ defines a linear pencil on \mathfrak{g}_λ^* . Since $P_\alpha|_{\mathfrak{g}_\lambda}$ is defined up to a multiplicative constant, the pencil is well-defined. Denote this pencil by $d_\lambda \Pi(x)$.

Definition 16. The pencil $d_\lambda \Pi(x)$ will be called the λ -linearization of the pencil Π at the point x .

2.4 The non-degeneracy criterion

Definition 17. A pencil Π will be called diagonalizable at a point x , if for each $\lambda \in \Lambda(x)$ and any $\alpha \neq \lambda$ the following is true

$$\dim \text{Ker} (P_\alpha(x)|_{\text{Ker } P_\lambda(x)}) = \text{corank } \Pi(x).$$

Remark 2.4.1. In terms of the Jordan-Kronecker decomposition for the pencil Π at a point x this means that all Jordan blocks J_{k_i, λ_i} have size 1×1 , i.e. all k_i are equal to 1.

Theorem 8 (The non-degeneracy criterion). *Let $O(\alpha, x)$ be a symplectic leaf of a bracket P_α passing through x . Assume that P_α is regular at x (or, which is the same, $O(\alpha, x)$ is a symplectic leaf of maximal dimension). Then the singular point x of the integrable system $\mathcal{F}|_{O(\alpha, x)}$ is non-degenerate if and only if the following two conditions hold:*

1. Π is diagonalizable at point x .
2. For each $\lambda \in \Lambda(x)$ the linear pencil $d_\lambda \Pi(x)$ is non-degenerate.

The proof of this theorem is given in Section 5.5.

The following example shows that Theorem 8 is wrong if we add to the system \mathcal{F} a Casimir function of a bracket, singular at x (recall that \mathcal{F} , by definition, is generated by Casimir functions of regular brackets).

Example 2.4.1 (A.V.Bolsinov). Consider $\mathfrak{so}(3)^*$ with the following bracket

$$P_0 = (x^2 + y^2 + z^2)P_{\mathfrak{so}(3)},$$

where $P_{\mathfrak{so}(3)}$ is the standard Lie-Poisson bracket on $\mathfrak{so}(3)$.

Consider also any constant bracket of rank 2 and denote it by P_∞ . It is easy to check that P_0 and P_∞ are compatible.

The Casimir function of P_0 is $x^2 + y^2 + z^2$. The restriction of this function to the symplectic leaf of P_∞ , passing through the origin, defines an integrable system. The origin is a non-degenerate elliptic point of this system. However, the linearization of our pencil at the origin is zero, therefore the conditions of Theorem 8 do not hold.

But if we take a Casimir function of a regular bracket, it will look like

$$(x^2 + y^2 + z^2)^2 + \text{linear terms},$$

and its restriction to the symplectic leaf of P_∞ is degenerate, as it is predicted by Theorem 8.

The problem is that if we consider the set of the Casimir functions of all brackets of the pencil, the function $x^2 + y^2 + z^2$ will be an “isolated point” in this set. But if the set of all Casimir functions formed a smooth family, then Theorem 8 could be applied even if \mathcal{F} contains Casimir functions of a bracket

singular at a given point (for example, we could take as \mathcal{F} the set of Casimir functions of all brackets). This can be proved by continuity arguments.

Theorem 9 (Type theorem). *Assume that the conditions of Theorem 8 hold. Then the type of the singular point x is (k_e, k_h, k_f) , where*

$$\begin{aligned} k_e &= \sum_{\lambda \in \Lambda(x) \cap \overline{\mathbb{R}}} k_e(\lambda), \\ k_h &= \sum_{\lambda \in \Lambda(x) \cap \overline{\mathbb{R}}} k_h(\lambda), \\ k_f &= \sum_{\lambda \in \Lambda(x) \cap \overline{\mathbb{R}}} k_f(\lambda) + \frac{1}{2} \sum_{\substack{\lambda \in \Lambda(x), \\ \text{Im } \lambda > 0}} (\dim_{\mathbb{C}} \text{Ker } P_\lambda - \text{corank } \Pi), \end{aligned}$$

and $(k_e(\lambda), k_h(\lambda), k_f(\lambda))$ is the type of $\text{Sing}(d_\lambda \Pi(x))$.

In other words, the type of a non-degenerate singular point x is the “sum” of types of $\text{Sing}(d_\lambda \Pi(\lambda))$ for all $\lambda \in \Lambda(x)$. The second summand in the formula for k_f appears, because $\text{Sing}(d_\lambda \Pi(\lambda))$ is always a focus-focus singularity if λ is not real.

The proof of Theorem 9 is given in Section 5.5.

Taking into account the Eliasson theorem (Theorem 3), Theorem 9 can be reformulated as follows:

Theorem 10 (Bihamiltonian linearization theorem). *Assume that the conditions of Theorem 8 hold. Then the Liouville foliation of the system $\mathcal{F} |_{O(\alpha, x)}$ is locally symplectomorphic to*

$$\left(\prod_{\substack{\lambda \in \Lambda(x), \\ \text{Im } \lambda \geq 0}} \text{Sing}(d_\lambda \Pi(x)) \right) \times (\mathbb{R}^k \times \mathbb{R}^k),$$

where $\mathbb{R}^k \times \mathbb{R}^k$ is a trivial Lagrangian foliation and

$$k = \frac{1}{2} \left(\text{rank } \Pi - \sum_{\lambda \in \Lambda(x)} (\dim \text{Ker } P_\lambda - \text{corank } \Pi) \right)$$

is the rank of x .

A question arises: is it possible to generalise this theorem to the case of degenerate linearizations?

Conjecture 1 (Bihamiltonian linearization conjecture). *Assume that*

1. *A pencil Π is diagonalizable at a point x .*
2. *For each singular λ the linearization $d_\lambda \Pi(x)$ is “nice” (for example, $\mathfrak{g}_\lambda(x)$ is reductive and P_α is exact on $\mathfrak{g}_\lambda(x)$).*

Then for each regular α the statement of Theorem 10 holds.

If the conjecture is true, then any bihamiltonian system is locally equivalent to a system of “argument shift type”, assuming that the linearization of the initial system is “nice”.

Chapter 3

Zero order theory

In this chapter we study properties of two compatible Poisson brackets at a point, i.e. properties of two skew-symmetric bilinear forms on a vector space. Note that all of these properties are known and can be deduced from the Jordan-Kronecker theorem.

3.1 Geometry of a pair of skew-symmetric forms on a vector space

Consider a pencil Π and a point x . Define

$$\Lambda = \{\lambda \in \overline{\mathbb{C}} : \text{rank } P_\lambda(x) < \text{rank } \Pi(x)\}.$$

$$L = \sum_{\lambda \in \overline{\mathbb{R}} \setminus \Lambda} \text{Ker } P_\lambda(x) \subset \mathbb{T}_x^*M.$$

Proposition 3.1.1 (Lagrange interpolation formula). *Let Π be a Poisson pencil, $\alpha \neq \beta$. Then*

$$P_\gamma(\xi, \psi)(x) = \frac{\beta - \gamma}{\beta - \alpha} P_\alpha(\xi, \psi)(x) + \frac{\gamma - \alpha}{\beta - \alpha} P_\beta(\xi, \psi)(x)$$

for any $\xi, \psi \in \mathbb{T}_x^*M$.

Proof. By definition we have

$$P_\alpha = P_0 + \alpha P_\infty,$$

$$P_\beta = P_0 + \beta P_\infty.$$

Expressing P_0 and P_∞ and substituting the result into the formula

$$P_\gamma = P_0 + \gamma P_\infty,$$

we obtain the desired statement. \square

Proposition 3.1.2.

1. *If $\alpha \neq \beta$, then $\text{Ker } P_\alpha$ is orthogonal to $\text{Ker } P_\beta$ with respect to any bracket of the pencil.*
2. *If $\alpha \notin \Lambda$, then $\text{Ker } P_\alpha$ is isotropic with respect to any bracket of the pencil.*

Proof. Let $\xi \in \text{Ker } P_\alpha, \psi \in \text{Ker } P_\beta$. We have

$$P_\alpha(\xi, \psi) = 0,$$

$$P_\beta(\xi, \psi) = 0$$

If $\alpha \neq \beta$ then, taking into account Proposition 3.1.1, we have $P_\gamma(\xi, \psi) = 0$ for any γ .

Further if α is regular then

$$\text{Ker } P_\alpha = \lim_{x \rightarrow \alpha} \text{Ker } P_x.$$

Passing to the limit in the equality $P_\gamma(\text{Ker } P_x, \text{Ker } P_\alpha) = 0$ we obtain the second statement. \square

Proposition 3.1.3. *The space L is isotropic with respect to any bracket of the pencil.*

Proof. By definition L is the direct sum of the kernels of the regular brackets. By Proposition 3.1.2, all these kernels are isotropic and orthogonal to each other with respect to any bracket of the pencil. Therefore L is isotropic with respect to all these brackets. \square

Proposition 3.1.4. *Orthogonal complement to L does not depend on the choice of a bracket of the pencil.*

Proof. Assume that $P_\alpha(\xi, L) = 0$. We need to show that $P_\beta(\xi, L) = 0$ for any β which means that $P_\beta(\xi, \text{Ker } P_\gamma) = 0$ for any regular γ . We have

$$P_\gamma(\xi, \text{Ker } P_\gamma) = 0,$$

$$P_\alpha(\xi, \text{Ker } P_\gamma) = 0, \text{ because } P_\alpha(\xi, L) = 0, \text{Ker } P_\gamma \subset L.$$

If $\gamma \neq \alpha$ these two equalities imply $P_\beta(\xi, \text{Ker } P_\gamma) = 0$ (taking into account Proposition 3.1.2). And if $\gamma = \alpha$ then α is regular, and our statement can be proven by passing to the limit. \square

Proposition 3.1.5. *Let $b(x, y)$ be a skew-symmetric bilinear form on a vector space V and let W be a vector subspace in V . Then $\dim W^\perp = \dim V - \dim W + \dim(W \cap \text{Ker } b)$, where W^\perp is the orthogonal complement to W with respect to the form b .*

Proof. Consider the operator $\bar{b} : V \rightarrow V^*$ given by the formula

$$\bar{b}(x)(y) = b(x, y).$$

By definition $\text{Ker } \bar{b} = \text{Ker } b$, therefore

$$\text{Ker } (\bar{b} |_W) = \text{Ker } b \cap W.$$

Consequently,

$$\dim \bar{b}(W) = \dim W - \dim(\text{Ker } b \cap W).$$

But

$$W^\perp = \text{Ann } \bar{b}(W),$$

which gives us the desired formula. \square

Proposition 3.1.6. *Any regular bracket of the pencil is non-degenerate on L^\perp/L .*

Proof. First of all we should say that the forms P_α are well-defined on L^\perp/L , because L is isotropic with respect to all these forms. Since α is regular, there is an inclusion $\text{Ker } P_\alpha \subset L$. Therefore, taking into account Proposition 3.1.5,

$$\dim L^\perp = n - \dim L + \dim \text{Ker } P_\alpha,$$

where n is the dimension of the whole space. Furthermore

$$\dim(L^\perp)^\perp = n - \dim L^\perp + \dim \text{Ker } P_\alpha = \dim L.$$

But this means that $(L^\perp)^\perp = L$, which implies non-degeneracy of P_α on L^\perp/L . \square

Lemma 3.1.1. *Denote $W = \sum_{i=1}^k \text{Ker } P_{\alpha_i}$ and let α and β be different from all α_k . Then*

$$\dim(W \cap \text{Ker } P_\alpha) = \dim(W \cap \text{Ker } P_\beta).$$

Proof. Decompose each $\text{Ker } P_{\alpha_i}$ into a sum

$$\text{Ker } P_{\alpha_i} = \left(\text{Ker } P_{\alpha_i} \cap \left(\sum_{j=1}^{i-1} \text{Ker } P_{\alpha_j} \right) \right) \oplus V_i.$$

Obviously, we have

$$L = \bigoplus_{i=1}^k V_k$$

and for each $\xi \in (\text{Ker } P_\alpha \cap W)$ there exists a unique decomposition

$$\xi = \sum \xi_j, \quad \xi_j \in V_j.$$

Define

$$\pi_\alpha^\beta(\xi) = \sum \frac{\alpha_j - \alpha}{\alpha_j - \beta} \xi_j.$$

We will have

$$\begin{aligned} P_\beta(\pi_\alpha^\beta(\xi), \psi) &= P_\beta \left(\sum \frac{\alpha_j - \alpha}{\alpha_j - \beta} \xi_j, \psi \right) = \sum \frac{\alpha_j - \alpha}{\alpha_j - \beta} P_\beta(\xi_j, \psi) = \\ &= \sum \frac{\alpha_j - \alpha}{\alpha_j - \beta} \left(\frac{\alpha_j - \beta}{\alpha_j - \alpha} P_\alpha(\xi_j, \psi) + \frac{\beta - \alpha}{\alpha_j - \alpha} P_{\alpha_j}(\xi_j, \psi) \right) = \\ &= \sum P_\alpha(\xi_j, \psi) = P_\alpha(\xi, \psi) = 0. \end{aligned}$$

Consequently, $\pi_\alpha^\beta(\text{Ker } P_\alpha \cap W) = \text{Ker } P_\beta \cap W$. Also note that the map π_α^β is invertible: the inverse is given by the formula

$$\pi_\beta^\alpha(\xi) = \sum \frac{\alpha_j - \beta}{\alpha_j - \alpha} \xi_j.$$

Therefore π_α^β is an isomorphism between $\text{Ker } P_\alpha \cap W$ and $\text{Ker } P_\beta \cap W$, and the dimensions of these spaces are equal. \square

Lemma 3.1.2. *Let $k = \dim L$. Then for any regular different $\alpha_1, \dots, \alpha_k$*

$$\sum_{i=1}^k \text{Ker } P_{\alpha_i} = L.$$

Proof. Let

$$L_m = \sum_{i=1}^m \text{Ker } P_{\alpha_i}.$$

By Lemma 3.1.1 for any α different from α_i , where $i \in \{1, \dots, m\}$, we have

$$\dim(L_m \cap \text{Ker } P_\alpha) = \dim(L_m \cap \text{Ker } P_{\alpha_{m+1}}).$$

If $\text{Ker } P_{\alpha_{m+1}} \subset L_m$ then

$$\dim(L_m \cap \text{Ker } P_\alpha) = \dim \text{Ker } P_{\alpha_{m+1}} = \text{corank } \Pi.$$

But if α is regular then $\dim \text{Ker } P_\alpha = \text{corank } \Pi$ and therefore $\text{Ker } P_\alpha \subset L_m$. This implies $L \subset L_m$, which means that $L_m = L$.

Consequently, either there exists $m \leq \dim L$ such that $L_m = L$, and in this case everything is proven, or there exists a sequence of strict inclusions

$$L_1 \subset L_2 \subset \cdots \subset L_k, \text{ where } k = \dim L.$$

Since L_1 is non-empty and all inclusions are strict, we have $\dim L_k \geq k = \dim L$, therefore $L_k = L$, q.e.d. \square

Corollary 3.1.1. *Let \mathcal{F} be a system of functions defined in Section 1.5. Then $d\mathcal{F} = L$.*

Proof. \mathcal{F} is generated by local Casimir functions of infinite number of regular brackets of the pencil. Differentials of local Casimir functions of a regular bracket generate kernel of this bracket. Therefore $d\mathcal{F}$ is a sum of kernels of infinite number of regular brackets of the pencil. But it is enough to take $k = \dim L$ of them to generate L . \square

Lemma 3.1.3. $\dim(\text{Ker } P_\lambda \cap L) = \text{corank } \Pi$ for all λ .

Proof. By Lemma 3.1.2 there exists a decomposition

$$L = \sum_{i=1}^k \text{Ker } P_{\alpha_i}.$$

By Lemma 3.1.1

$$\dim(\text{Ker } P_\lambda(x) \cap L) = \dim(\text{Ker } P_\alpha(x) \cap L)$$

for any α different from all α_i . But if α is regular we have

$$\dim(\text{Ker } P_\alpha(x) \cap L) = \dim \text{Ker } P_\alpha = \text{corank } \Pi,$$

which proves our Lemma. \square

3.2 The recursion operator

Since P_β is non-degenerate on L^\perp/L for any regular β , the recursion operator $R_\alpha^\beta = P_\beta^{-1}P_\alpha$ for such β is well-defined.

Proposition 3.2.1. *For any α, γ and regular β, δ there exist constants a, b, c, d such that*

$$R_\alpha^\beta = (cR_\gamma^\delta + dE)^{-1}(aR_\gamma^\delta + bE).$$

Consequently, the operators R_α^β and R_γ^δ commute.

Proof. By definition we have

$$\begin{aligned} R_\alpha^\beta &= P_\beta^{-1}P_\alpha, \\ R_\gamma^\delta &= P_\delta^{-1}P_\gamma. \end{aligned}$$

Using interpolation formula we may write

$$P_\alpha = aP_\gamma + bP_\delta, P_\beta = cP_\gamma + dP_\delta,$$

which implies

$$\begin{aligned} R_\alpha^\beta &= (cP_\gamma + dP_\delta)^{-1}(aP_\gamma + bP_\delta) = \\ &= (P_\delta(cR_\gamma^\delta + dE))^{-1}P_\delta(aR_\gamma^\delta + bE) = (cR_\gamma^\delta + dE)^{-1}(aR_\gamma^\delta + bE), \end{aligned}$$

q.e.d. □

Remark 3.2.1. Since R_α^β is parametrized by α and β , we have a two-dimensional family of recursion operators. But usually it does not matter which of them to consider. In this case we will simply say “the recursion operator”.

Lemma 3.2.1. *The eigenspaces of the recursion operator are pairwise orthogonal with respect to all brackets of the pencil.*

Remark 3.2.2. We say “the recursion operator” here, cause all recursion operators have common eigenspaces.

Proof of Lemma 3.2.1. Without loss of generality we may assume that the bracket P_∞ is regular and consider the operator R_0^∞ .

It is easy to see that

$$\text{Ker} (R_0^\infty - \lambda E) = \text{Ker} (P_{-\lambda} |_{L^\perp/L}),$$

where E is the identity operator.

But the kernels of the brackets of the pencil are pairwise orthogonal, which proves the desired statement. \square

Proposition 3.2.2. *A pencil is diagonalizable at x if and only if the corresponding recursion operator is diagonalizable (over \mathbb{C}).*

Remark 3.2.3. Lemma 3.2.1 implies that if R_γ^δ is diagonalizable, then R_α^β is diagonalizable as well.

Proof of Proposition 3.2.2. Suppose that the recursion operator is diagonalizable. Then the (complexified) space L^\perp/L is decomposed into the sum of the eigenspaces of the recursion operator. All summands are orthogonal to each other, therefore any regular bracket of the pencil is non-degenerate on these summands, which means that

$$\text{Ker} (P_\alpha |_{\text{Ker} P_\lambda / (\text{Ker} P_\lambda \cap L)}) = 0.$$

But this implies

$$\text{Ker} (P_\alpha |_{\text{Ker} P_\lambda}) = \text{Ker} P_\lambda \cap L.$$

Taking into account Lemma 3.1.3 we obtain the following

$$\dim \text{Ker} P_\alpha |_{\text{Ker} P_\lambda} = \text{corank } \Pi,$$

q.e.d.

Now let the pencil be diagonalizable at x . This immediately implies that P_α is non-degenerate on $\text{Ker } P_\lambda / (\text{Ker } P_\lambda \cap L)$ for any λ . Now suppose that the recursion operator R_0^∞ has a non-trivial Jordan block for some eigenvalue λ . This means that

$$(R_0^\infty - \lambda E)y = x$$

for some non-zero $x, y \in L^\perp/L$.

Then for any $z \in L^\perp/L$ we have

$$P_{-\lambda}(y, z) = P_\infty(x, z).$$

If $z \in \text{Ker } P_{-\lambda} / (\text{Ker } P_{-\lambda} \cap L)$, then $P_\infty(x, z) = 0$. But this means that P_∞ has a kernel on $\text{Ker } P_{-\lambda} / (\text{Ker } P_{-\lambda} \cap L)$. Contradiction. \square

Corollary 3.2.1. *If a pencil is diagonalizable at point x , then the space L^\perp/L is decomposed into the sum of the real parts of the eigenspaces of the recursion operator. The summands of this decomposition are pairwise orthogonal with respect to all brackets of the pencil.*

Chapter 4

First order theory

4.1 Definition of the operator $D_f P$

In this section we will define the operator $D_f P$, which will be very useful later. Let P be a Poisson bracket on M , $x \in M$, $df(x) \in \text{Ker } P(x)$. Define $D_f P(x) : T_x^* M \rightarrow T_x^* M$ by the following formula

$$D_f P(x)(\xi) = d\{f, g\}_P,$$

where g is an arbitrary function such that $dg(x) = \xi$.

Let

$$C_k^{ij} = \frac{\partial P^{ij}}{\partial x^k}.$$

Proposition 4.1.1.

$$(D_f P(x)(\xi))_k = C_k^{ij} \frac{\partial f}{\partial x^i} \xi_j + P^{ij} \frac{\partial^2 f}{\partial x^i \partial x^k} \xi_j$$

and therefore does not depend on the choice of g .

Proof.

$$\frac{\partial}{\partial x^k} \{f, g\}_P = \frac{\partial}{\partial x^k} (P^{ij} \frac{\partial f}{\partial x^i} \frac{\partial g}{\partial x^j}) = C_k^{ij} \frac{\partial f}{\partial x^i} \xi_j + P^{ij} \frac{\partial^2 f}{\partial x^i \partial x^k} \xi_j,$$

q.e.d. □

Proposition 4.1.2. $D_f P(x)$ is dual to the linearisation A_f of a vector field $\text{sgrad } f = P \text{d}f$ at a point x . In other words,

$$\langle D_f P(x)(\xi), v \rangle = \langle \xi, A_f(v) \rangle$$

for any $v \in T_x M$.

Proof. By definition

$$A_f(v) = \frac{\partial}{\partial v} \frac{\partial}{\partial (\text{sgrad } f)}.$$

Let $\xi = \text{d}g$. Then

$$\langle \xi, A_f(v) \rangle = \frac{\partial}{\partial v} \frac{\partial g}{\partial (\text{sgrad } f)} = \frac{\partial \{f, g\}}{\partial v} = \langle D_f P(x)(\xi), v \rangle,$$

q.e.d. □

Proposition 4.1.3. $D_f P(x)$ is skew-symmetric with respect to P , which means

$$P(D_f P(x)(\xi), \eta) + P(\xi, D_f P(x)(\eta)) = 0$$

Proof. By definition we have

$$D_f P(x)(\xi) = \text{d}\{f, g\}(x), \text{ where } \text{d}g(x) = \xi,$$

$$D_f P(x)(\eta) = \text{d}\{f, h\}(x), \text{ where } \text{d}h(x) = \eta.$$

Therefore

$$P(D_f P(x)(\xi), \eta) = \{\{f, g\}, h\}(x),$$

$$P(\xi, D_f P(x)(\eta)) = \{\{h, f\}, g\}(x),$$

and

$$\begin{aligned} P(D_f P(x)(\xi), \eta) + P(\xi, D_f P(x)(\eta)) &= \\ &= \{\{f, g\}, h\}(x) + \{\{h, f\}, g\}(x) = -\{\{g, h\}, f\}(x) = 0, \end{aligned}$$

because $\text{d}f(x) \in \text{Ker } P$. □

Proposition 4.1.4. *Let $W \subset T_x^*M$ be invariant under $D_fP(x)$. Then W^\perp is also invariant.*

Proof. Let $\xi \in W^\perp, \eta \in W$. Then

$$P(D_fP(x)(\xi), \eta) = -P(\xi, D_fP(x)(\eta)) = 0,$$

because W is invariant. Therefore $D_fP(x)(\xi) \in W^\perp$, q.e.d. □

Proposition 4.1.5. *The kernel of P at a point x is invariant with respect to $D_fP(x)$.*

Proof. Indeed, $\text{Ker } P = (T_x^*M)^\perp$ and, therefore, is invariant. □

Proposition 4.1.6. *Let $\xi \in \text{Ker } P$. Then*

$$D_fP(x)(\xi) = [df(x), \xi],$$

where $[,]$ is the commutator in the linearization of P .

Proof. By definition

$$D_fP(x)(\xi) = d\{f, g\}(x), \text{ where } dg(x) = \xi.$$

On the other hand,

$$[df(x), \xi] = [df(x), dg(x)] = d\{f, g\}(x)$$

by the definition of linearization. Proposition is proved. □

Proposition 4.1.7. *If x is regular, then $D_fP(x)$ vanishes on $\text{Ker } P$.*

Proof. Indeed, the linearization of P is Abelian in this case. □

4.2 Operators $D_f P_\alpha$ for $f \in \mathcal{F}$

The following two lemmas will allow us to rewrite the operator $D_f P_\alpha$, $f \in \mathcal{F}$ as $D_g P_\lambda$ for an appropriate function g .

Lemma 4.2.1. *Let*

$$f = \sum_{i=1}^k f_{\alpha_i},$$

where f_{α_i} is a Casimir function of P_{α_i} .

Let also $df(x) \in \text{Ker } P_\alpha(x)$.

Let $\lambda \in \mathbb{C}$ and $\lambda \neq \alpha_i$ for any i . Consider a function

$$g = \sum_{i=1}^k \frac{\alpha - \alpha_i}{\lambda - \alpha_i} f_{\alpha_i}.$$

Then

1. $dg(x) \in \text{Ker } P_\lambda$,
2. $D_f P_\alpha(x) = D_g P_\lambda(x)$.

Proof.

1. We have

$$\begin{aligned} P_\lambda(dg, \xi) &= P_\lambda \left(\sum \frac{\alpha - \alpha_i}{\lambda - \alpha_i} df_{\alpha_i}, \xi \right) = \sum \frac{\alpha - \alpha_i}{\lambda - \alpha_i} P_\lambda(df_{\alpha_i}, \xi) = \\ &= \sum P_\alpha(df_{\alpha_i}, \xi) = P_\alpha(df, \xi) = 0. \end{aligned}$$

2. We have

$$\begin{aligned} \langle D_g P_\lambda(x), dh \rangle &= dP_\lambda(dg, dh) = d \sum \frac{\alpha - \alpha_i}{\lambda - \alpha_i} P_\lambda(df_{\alpha_i}, dh) = \\ &= d \sum P_\alpha(df_{\alpha_i}, dh) = dP_\alpha(df, dh) = \langle D_f P_\alpha(x), dh \rangle. \end{aligned}$$

□

Lemma 4.2.2. *Let*

$$f = \sum_{i=1}^k f_{\alpha_i},$$

where f_{α_i} is a Casimir function of P_{α_i} .

Let also $df(x) \in \text{Ker } P_{\alpha}(x)$.

Suppose that $\lambda = \alpha_j$ and α_j is regular at a point x . Then there exists a function $g \in \mathcal{F}$ such that

1. $dg(x) \in \text{Ker } P_{\lambda}$,
2. $D_f P_{\alpha}(x) = D_g P_{\lambda}(x)$.

Proof. Consider a smooth family f_{ν} such that $f_{\nu}|_{\nu=\alpha_j} = f_{\alpha_j}$ and f_{ν} is a Casimir function of P_{ν} . Let

$$f(\nu) = \sum_{i=1}^k f_{\alpha_i} - f_{\alpha_j} + f_{\nu}$$

By the previous lemma, for each ν in a sufficiently small punctured neighbourhood of α_j we have

$$D_{f(\nu)} P_{\alpha}(x) = D_{g(\nu)} P_{\lambda}(x)$$

for some function $g(\nu) \in \mathcal{F}$. Since $D_{f(\nu)} P_{\alpha}(x) \rightarrow D_f P_{\alpha}(x)$ as $\nu \rightarrow \alpha_j$, the operator $D_f P_{\alpha}(x)$ belongs to the closure of the set $\{D_g P_{\lambda}\}_{g \in \mathcal{F}, dg \in \text{Ker } P_{\lambda}}$. But this latter set is a finite-dimensional vector space, therefore it contains $D_f P_{\alpha}(x)$, q.e.d. \square

Corollary 4.2.1. *Let $f \in \mathcal{F}$, $df(x) \in \text{Ker } P_{\alpha}$. Then $D_f P_{\alpha}$ is skew-symmetric with respect to **all** brackets of the pencil.*

Proof. Taking into account Lemmas 4.2.1, 4.2.2, we see that for each λ there exists a function g such that

$$D_f P_{\alpha} = D_g P_{\lambda}.$$

But $D_g P_{\lambda}$ is skew-symmetric with respect to P_{λ} . \square

Proposition 4.2.1. *Let $f \in \mathcal{F}$, $df(x) \in \text{Ker } P_\alpha$. Then $D_f P_\alpha$ vanishes on L .*

Proof. It suffices to show that $D_f P_\alpha$ vanishes on $\text{Ker } P_\gamma$ for each regular γ . As it was shown, there exists a function g such that $D_f P_\alpha = D_g P_\gamma$. Due to the regularity of P_γ the operator $D_g P_\gamma$ vanishes on $\text{Ker } P_\gamma$ (see Proposition 4.1.7), q.e.d. \square

Consequently, the operators $D_f P_\alpha$ are well-defined on the space L^\perp/L . By Corollary 4.2.1 the following is true

Proposition 4.2.2. *Let $f \in \mathcal{F}$, $df(x) \in \text{Ker } P_\alpha$. Then*

$$D_f P_\alpha |_{L^\perp/L} \in \mathfrak{sp}(L^\perp/L, P_\beta)$$

for any regular β , i.e. operators $D_f P_\alpha |_{L^\perp/L}$ are bi-symplectic.

Corollary 4.2.2. *Let $f \in \mathcal{F}$, $df(x) \in \text{Ker } P_\alpha$. Then $D_f P_\alpha |_{L^\perp/L}$ commutes with the recursion operator.*

Proof. Let $D = D_f P_\alpha |_{L^\perp/L}$. Due to the skew-symmetry we have

$$DP_\alpha + P_\alpha D^T = 0,$$

$$DP_\beta + P_\beta D^T = 0,$$

which implies

$$DR = DP_\alpha^{-1} P_\beta = P_\alpha^{-1} D^T P_\beta = P_\alpha^{-1} P_\beta D = RD,$$

q.e.d. \square

Corollary 4.2.3. *Let $f \in \mathcal{F}$, $df(x) \in \text{Ker } P_\alpha$. Then $D_f P_\alpha |_{L^\perp/L}$ preserves the eigenspaces of the recursion operator.*

The following Proposition allows us to calculate $D_f P_\alpha$ on such an eigenspace.

Proposition 4.2.3.

1. Let $f = \sum_{i=1}^k f_{\alpha_i}$, where f_{α_i} is a Casimir function of a regular bracket P_{α_i} . Let also $df(x) \in \text{Ker } P_\alpha$, $\lambda \in \Lambda(x)$. Then

$$D_f P_\alpha |_{\text{Ker } P_\lambda} (\xi) = \left[\sum_{i=1}^k \frac{\alpha - \alpha_i}{\lambda - \alpha_i} df_{\alpha_i}, \xi \right],$$

where $[\cdot, \cdot]$ is the commutator in \mathfrak{g}_λ .

2. The following sets of operators are equal

$$\{D_f P_\alpha |_{\text{Ker } P_\lambda}\}_{f \in \mathcal{F}, df \in \text{Ker } P_\alpha} = \{\text{ad}_\xi\}_{\xi \in \mathfrak{g}_\lambda \cap L},$$

where ad_ξ is the adjoint operator in \mathfrak{g}_λ

Proof. This directly follows from Proposition 4.1.6 and Lemma 4.2.1. \square

Now note that if the recursion operators are diagonalizable, we are able to express $D_f P_\alpha$ on the whole L^\perp/L via adjoint operators. Indeed, L^\perp/L in this case is going to be the direct sum of $\text{Ker } P_\lambda |_{L^\perp/L}$, $\lambda \in \Lambda(x)$.

Denote

$$\mathfrak{D} = \{D_f P_\alpha |_{L^\perp/L}\}_{f \in \mathcal{F}, df \in \text{Ker } P_\alpha} \subset \mathfrak{sp}(L^\perp/L).$$

By Lemmas 4.2.1, 4.2.2, the subspace \mathfrak{D} does not depend on the choice of α .

Lemma 4.2.3. \mathfrak{D} is invariant with respect to the recursion operator. In other words, if $D \in \mathfrak{D}$, then $RD \in \mathfrak{D}$.

Proof. Without loss of generality we may assume that $D = D_f P_\alpha$, where α is regular. Choose a Casimir function f_α of P_α such that $df_\alpha(x) = df(x)$. Then

$$RD = P_\beta P_\alpha^{-1} D = P_\beta P_\alpha^{-1} D_{f-f_\alpha} P_\alpha = P_\beta d^2(f - f_\alpha) = D_{f-f_\alpha} P_\beta \in \mathfrak{D}.$$

\square

Corollary 4.2.4. *Let $\mathfrak{D}_\lambda = \left\{ D_f P_\alpha \big|_{\operatorname{Re} \operatorname{Ker} (P_\lambda|_{\mathbb{C} \otimes L^\perp / L})} \right\}_{f \in \mathcal{F}, df \in \operatorname{Ker} P_\alpha}$. Suppose that the pencil is diagonalizable. Then $\mathfrak{D} = \bigoplus \mathfrak{D}_\lambda$.*

4.3 Operator $D_f P$ and linearizations of hamiltonian vector fields

Let us consider the integrable system $\mathcal{F}|_{O(\alpha, x)}$ defined in Section 1.5. We assume that the symplectic leaf $O(\alpha, x)$ is regular.

The tangent space $T_x O$ is equipped with a natural symplectic form ω_α given by the formula

$$\omega_\alpha(P_\alpha df, P_\alpha dg) = \{f, g\}_\alpha(x).$$

Let

$$W = \{\operatorname{sgrad}_\alpha f = P_\alpha df, \text{ where } f \in F\}.$$

Let W^\perp be the orthogonal complement to it (with respect to ω_α). Then the space W^\perp/W is symplectic with respect to ω_α .

Proposition 4.3.1. *Consider the map $P_\alpha : T_x^* M \rightarrow T_x M$. The following is true:*

1. $\omega_\alpha(P_\alpha(\xi), P_\alpha(\psi)) = P_\alpha(\xi, \psi)$.
2. $P_\alpha(L) = W$.
3. $P_\alpha(L^\perp) = W^\perp$.
4. Let A_f be the linearization of $\operatorname{sgrad} f$ on W^\perp/W , where $df \in \operatorname{Ker} P_\alpha$.

Then the following diagram is commutative:

$$\begin{array}{ccc}
L^\perp/L & \xrightarrow{D_f P_\alpha} & L^\perp/L \\
\downarrow P_\alpha & & \downarrow P_\alpha \\
W^\perp/W & \xrightarrow{A_f} & W^\perp/W
\end{array}$$

Proof.

1. Let $\xi, \psi \in T_x^*M$. Choosing functions f, g such that $df = \xi, dg = \psi$, we will have

$$\begin{aligned}
\omega_\alpha(P_\alpha(\xi), P_\alpha(\psi)) &= \omega_\alpha(P_\alpha(df), P_\alpha(dg)) = \\
&= \omega_\alpha(\text{sgrad } f, \text{sgrad } g) = \{f, g\}_\alpha(x) = P_\alpha(\xi, \psi),
\end{aligned}$$

q.e.d.

2. Indeed, by definition $W = P_\alpha d\mathcal{F}$. On the other hand, $d\mathcal{F} = L$.
3. Let $\xi \in L^\perp, v \in W$. Then $v = P_\alpha(\psi)$ for some $\psi \in L$. Therefore

$$\omega_\alpha(P_\alpha(\xi), v) = \omega_\alpha(P_\alpha(\xi), P_\alpha(\psi)) = P_\alpha(\xi, \psi) = 0.$$

Consequently, $P_\alpha(L^\perp) \subset W^\perp$. Now let $w \in W^\perp$. Since w lies in $T_x O$ we can find $\xi \in T_x^*M$ such that $w = P_\alpha(\xi)$. Let us show that $\xi \in L^\perp$. Let $\psi \in L$. Then

$$P_\alpha(\xi, \psi) = \omega_\alpha(P_\alpha(\xi), P_\alpha(\psi)) = \omega_\alpha(w, P_\alpha(\psi)).$$

Since $P_\alpha(\psi) \in W$, while $w \in W^\perp$, the latter expression vanishes, q.e.d.

4. We need to prove that

$$P_\alpha(D_f P_\alpha(\xi)) = A_f(P_\alpha(\xi)).$$

Let $\xi = dg(x)$. Then we have

$$\begin{aligned} P_\alpha(D_f P_\alpha(dg)) &= P_\alpha(d\{f, g\}_\alpha) = \text{sgrad}\{f, g\}_\alpha = \\ &= [\text{sgrad} f, \text{sgrad} g] = A_f(\text{sgrad} g) = A_f(P_\alpha(\xi)), \end{aligned}$$

q.e.d.

□

Corollary 4.3.1. *P_α defines a symplectomorphism between L^\perp/L and W^\perp/W . This symplectomorphism sends $D_f P_\alpha$ to A_f , which is the linearization of $\text{sgrad} f$.*

Corollary 4.3.2. *A singular point x is non-degenerate on a regular symplectic leaf of P_α if and only if the set of operators $D_f P_\alpha$, where $f \in \mathcal{F}$, $df \in \text{Ker} P_\alpha$, generate a Cartan subalgebra in $\mathfrak{sp}(L^\perp/L, P_\alpha)$. Type of the point x coincides with the type of the Cartan subalgebra.*

Proof. By definition x is non-degenerate if and only if the linearizations of the hamiltonian vector fields $\text{sgrad} f$, $f \in \mathcal{F}$ generate a Cartan subalgebra in $\mathfrak{sp}(W^\perp/W, \omega_\alpha)$. Now we need to apply the isomorphism constructed above.

□

Chapter 5

Proof of the main theorems

5.1 Non-degeneracy of linear pencils

Let $\Pi^{\mathfrak{g},A}$ be an integrable linear pencil. Construct the system \mathcal{F} for this pencil and consider the singular point 0 on the orbit of the regular bracket A . Due to Corollary 4.3.1 there is a symplectomorphism

$$A : L^\perp/L \rightarrow W^\perp/W,$$

which sends $D_f A$ to the linearization of $\text{sgrad } f$ for each $f \in \mathcal{F}$, $df \in \text{Ker } A$. Consequently, to check non-degeneracy and find the type we need to calculate operators $D_f A$ on L^\perp/L for $f \in \mathcal{F}$, $df \in \text{Ker } A$.

By Proposition 4.2.3 we have

$$\{D_f A|_{\text{Ker } P_0}\}_{f \in \mathcal{F}, df \in \text{Ker } A} = \{\text{ad}_\xi\}_{\xi \in L}.$$

But $\text{Ker } P_0 = \mathfrak{g}^*$, while $\text{Ker } A = L$, therefore

$$\{D_f A\}_{f \in \mathcal{F}, df \in \text{Ker } A} = \{\text{ad}_\xi\}_{\xi \in \text{Ker } A}.$$

Since $L^\perp = \mathfrak{g}^*$, we have

$$\{D_f A|_{L^\perp/L}\}_{f \in \mathcal{F}, df \in \text{Ker } A} = \{\text{ad}_\xi|_{\mathfrak{g}/\text{Ker } A}\}_{\xi \in \text{Ker } A},$$

which proves the following

Lemma 5.1.1. *An integrable linear pencil $\Pi^{\mathfrak{g},A}$ is non-degenerate if and only if the set of operators*

$$\{\text{ad}_\xi \mid_{\mathfrak{g}/\text{Ker } A}\}_{\xi \in \text{Ker } A}$$

is a Cartan subalgebra in $\mathfrak{sp}(\mathfrak{g}/\text{Ker } A, A)$. The type of $\text{Sing}(\Pi^{\mathfrak{g},A})$ coincides with the type of this subalgebra.

Remark 5.1.1. Since A is a skew-symmetric 2-form, the space $\mathfrak{g}/\text{Ker } A$ is symplectic. The condition of compatibility of A with the Lie-Poisson bracket implies that all operators ad_ξ , where $\xi \in \text{Ker } A$, are skew-symmetric with respect to A . Therefore, they generate an Abelian (see Proposition 2.1.3) subalgebra in $\mathfrak{sp}(\mathfrak{g}/\text{Ker } A, A)$. Now we see that non-degeneracy is equivalent to the fact that this subalgebra is a Cartan subalgebra.

Corollary 5.1.1. *If $\Pi^{\mathfrak{g},A}$ is non-degenerate, then $\text{Ker } A$ consists of ad-semisimple elements.*

Since $\text{Ker } A$ is a commutative subalgebra (see Proposition 2.1.3) which consists of semisimple elements, all operators $\text{ad}_\xi, \xi \in \text{Ker } A$ may be simultaneously diagonalized (over \mathbb{C}). Now we can consider “root” decomposition of \mathfrak{g} :

$$\mathfrak{g} = \text{Ker } A + \sum_{i=1}^n (V_{\lambda_i} + V_{-\lambda_i}),$$

where each $V_{\pm\lambda_i}$ is spanned by one common eigenvector corresponding to the eigenvalue $\pm\lambda(\xi)$. Eigenvalues enter in pairs because the operators ad_ξ are symplectic.

Remark 5.1.2. Note that all $V_{\pm\lambda_i}$ are one-dimensional by definition.

Proposition 5.1.1. *If $\text{Ker } A$ is diagonalizable, then the pencil is non-degenerate if and only if $\lambda_1, \dots, \lambda_n$ are linearly independent. Type of*

$Sing(\Pi^{\mathfrak{g},A})$ is (k_e, k_h, k_f) where k_e is the number of pure imaginary λ_i , k_h is the number of real λ_i , and k_f is the number of pairs of complex conjugate λ_i .

Proof. Consider the map

$$\text{ad}: \text{Ker } A \rightarrow \mathfrak{sp}(\mathfrak{g}/\text{Ker } A, A),$$

which sends ξ to the operator ad_ξ . We want the image of this map to be a Cartan subalgebra (see Lemma 5.1.1). Since it is abelian and diagonalizable, it is Cartan if and only if the dimension of it equals

$$n = \frac{1}{2} \dim(\mathfrak{g}/\text{Ker } A).$$

Obviously,

$$\dim \text{ad}(\text{Ker } A) = \dim_{\mathbb{C}} \langle \lambda_i \rangle,$$

where $\langle \lambda_i \rangle$ is the subspace in $(\text{Ker } A)_{\mathbb{C}}^*$ spanned by $\lambda_1, \dots, \lambda_n$. Therefore, $\text{ad}(\text{Ker } A)$ is a Cartan subalgebra if and only if the roots are linearly independent.

The second statement directly follows from the definition of type. \square

Corollary 5.1.2. *If $\Pi^{\mathfrak{g},A}$ is non-degenerate, then $\text{Ker } A$ is a Cartan subalgebra.*

5.2 Classification of non-degenerate linear pencils: the complex case

$\Pi^{\mathfrak{g},A}$ is non-degenerate $\Rightarrow \mathfrak{g}$ is non-degenerate, and $\text{Ker } A$ is a Cartan subalgebra.

Taking into account Corollary 5.1.2 and Proposition 5.1.1, it suffices to show that if a complex Lie algebra \mathfrak{g} admits a root decomposition

$$\mathfrak{g} = \mathfrak{h} + \sum_{i=1}^n (V_{\lambda_i} + V_{-\lambda_i}), \quad (5.1)$$

with linearly independent λ_i , then \mathfrak{g} is non-degenerate.

By definition we have

$$[\mathfrak{h}, \mathfrak{h}] = 0,$$

$$[h, x] = \lambda(h)x \text{ for } h \in \mathfrak{h}, x \in V_{\lambda}.$$

The following is standard

Proposition 5.2.1. *If $e_{\alpha} \in V_{\alpha}, e_{\beta} \in V_{\beta}$, then $[e_{\alpha}, e_{\beta}] \in V_{\alpha+\beta}$.*

Proof. Let $h \in \mathfrak{h}$. By definition we have

$$[h, e_{\alpha}] = \alpha(h)e_{\alpha},$$

$$[h, e_{\beta}] = \beta(h)e_{\beta}.$$

Therefore

$$[h, [e_{\alpha}, e_{\beta}]] = -[e_{\alpha}, [e_{\beta}, h]] - [e_{\beta}, [h, e_{\alpha}]] = \beta[e_{\alpha}, e_{\beta}] + \alpha[e_{\alpha}, e_{\beta}],$$

q.e.d. □

Since the roots are independent, $\alpha + \beta$ is a root if and only if $\beta = -\alpha$. Consequently, we have the following relations

$$[V_{\lambda_i}, V_{-\lambda_i}] \in \mathfrak{h},$$

$$[V_{\lambda_i}, V_{\pm\lambda_j}] = 0.$$

Let e_{λ} be a basis vector in V_{λ} . Denoting $h_{\lambda_i} = [e_{\lambda_i}, e_{-\lambda_i}]$, we will have

$$[h_{\lambda_i}, e_{\lambda_j}] = [[e_{\lambda_i}, e_{-\lambda_i}], e_{\lambda_j}] = 0$$

if $i \neq j$ due to the Jacobi identity. Therefore,

$$\lambda_j(h_{\lambda_i}) = 0$$

if $i \neq j$.

Now suppose that $\lambda_i(h_{\lambda_i}) \neq 0$ for some value of i . Then the triple $e_{\lambda_i}, e_{-\lambda_i}, h_{\lambda_i}$ generate a subalgebra isomorphic to $\mathfrak{so}(3, \mathbb{C})$. Let us show that it admits a complementary subalgebra in \mathfrak{g} .

Let

$$\tilde{\mathfrak{h}} = \{h \in \mathfrak{h} : \lambda_i(h) = 0\}.$$

Denote

$$\tilde{\mathfrak{g}} = \tilde{\mathfrak{h}} + \sum_{j \neq i} (V_{\lambda_j} + V_{-\lambda_j}).$$

Proposition 5.2.2. $\mathfrak{g} = \tilde{\mathfrak{g}} \oplus \mathfrak{so}(3, \mathbb{C})$

Proof. It is obvious that \mathfrak{g} can be decomposed into the sum of $\tilde{\mathfrak{g}}$ and $\mathfrak{so}(3)$ as a vector space. Therefore, it suffices to show that $\tilde{\mathfrak{g}}$ is a subalgebra and $[\tilde{\mathfrak{g}}, \mathfrak{so}(3)] = 0$.

1. $\tilde{\mathfrak{g}}$ is a subalgebra.

Indeed,

$$\tilde{\mathfrak{g}} = \tilde{\mathfrak{h}} + \sum_{j \neq i} (V_{\lambda_j} + V_{-\lambda_j})$$

and

$$[\tilde{\mathfrak{h}}, \tilde{\mathfrak{h}}] = 0,$$

$$[V_{\pm\lambda_j}, V_{\pm\lambda_k}] = 0 \quad j \neq k.$$

Therefore, it is sufficient to show that $[V_{\lambda_j}, V_{-\lambda_j}] \in \tilde{\mathfrak{h}}$ if $j \neq i$. But $[V_{\lambda_j}, V_{-\lambda_j}]$ is generated by h_{λ_j} and $\lambda_i(h_{\lambda_j}) = 0$, q.e.d.

2. $[\tilde{\mathfrak{g}}, \mathfrak{so}(3)] = 0$.

Indeed,

$$\tilde{\mathfrak{g}} = \tilde{\mathfrak{h}} + \sum_{j \neq i} (V_{\lambda_j} + V_{-\lambda_j}),$$

$$\mathfrak{so}(3) = \langle h_{\lambda_i} \rangle + (V_{\lambda_i} + V_{-\lambda_i})$$

and

$$[\tilde{\mathfrak{h}}, h_{\lambda_i}] = 0, \text{ because } \mathfrak{h} \text{ is abelian,}$$

$$[\tilde{\mathfrak{h}}, V_{\lambda_i} + V_{-\lambda_i}] = 0, \text{ because } \lambda_i(\tilde{\mathfrak{h}}) = 0,$$

$$[h_{\lambda_i}, V_{\lambda_j} + V_{-\lambda_j}] = 0, \text{ because } \lambda_j(h_{\lambda_i}) = 0,$$

$$[V_{\lambda_j} + V_{-\lambda_j}, V_{\lambda_i} + V_{-\lambda_i}] = 0.$$

□

Separating $\mathfrak{so}(3)$ summands for all i such that $\lambda_i(h_{\lambda_i}) \neq 0$, we obtain the following

Lemma 5.2.1. *There exists a decomposition*

$$(\mathfrak{g}, \mathfrak{h}) = (\mathfrak{g}_1, \mathfrak{h}_1) \oplus (\mathfrak{g}_2, \mathfrak{h}_2),$$

where

1. $\mathfrak{g}_1 = \bigoplus \mathfrak{so}(3, \mathbb{C})$ and \mathfrak{h}_1 is a Cartan subalgebra.
2. \mathfrak{g}_2 is solvable and admits decomposition (5.1) with respect to \mathfrak{h}_2 .

Proof. After the separation of all $\mathfrak{so}(3)$ summands we will have $\lambda_i(h_{\lambda_i}) = 0$ for all i . It is easy to see that the third derived subalgebra of such an algebra is zero. □

Now it suffices to study the solvable case.

As the first step we shall separate an Abelian summand. Decompose the center of \mathfrak{g} into a direct sum

$$Z(\mathfrak{g}) = (Z(\mathfrak{g}) \cap [\mathfrak{g}, \mathfrak{g}]) \oplus V.$$

It is obvious that V can be separated from \mathfrak{g} as a direct summand.

After separating an Abelian summand we may assume that

$$Z(\mathfrak{g}) \subset [\mathfrak{g}, \mathfrak{g}].$$

This means that the center is generated by $h_i = [e_i, e_{-i}]$.

Now decompose subalgebra \mathfrak{h} as follows

$$\mathfrak{h} = \langle h_1, \dots, h_k \rangle \oplus T.$$

Since $\lambda_i(h_{\lambda_j}) = 0$ for all i and j , all λ_i are linearly independent in T^* . Moreover, for each $t \in T$ there is i such that $\lambda_i(t) = 0$ (otherwise t belongs to the center, which is not possible, because the center is generated by h_i). Therefore, the set of λ_i is a basis in T^* and we can choose a basis t_1, \dots, t_k in T such that

$$\lambda_i(t_j) = \delta_{ij}.$$

Consequently, \mathfrak{g} is generated by e_i, e_{-i}, h_i, t_i with the following relations

$$\begin{aligned} [e_i, e_{-i}] &= h_i, \\ [e_i, e_j] &= 0 \text{ if } j \neq -i, \\ [t_i, e_i] &= e_i, \\ [t_i, e_{-i}] &= -e_i, \\ [t_i, e_j] &= 0 \text{ if } j \neq \pm i, \\ [h_i, \mathfrak{g}] &= 0, \end{aligned}$$

$$[t_i, t_j] = 0,$$

$$[t_i, h_j] = 0$$

If all h_i were linearly independent, our algebra could be decomposed into a direct sum of $\mathfrak{g}_{\diamond}^{\mathbb{C}}$ -subalgebras. Since this is not necessarily the case, \mathfrak{g} is a quotient of such a direct sum by some central ideal.

Therefore, \mathfrak{g} is indeed non-degenerate.

\mathfrak{g} is non-degenerate and $\text{Ker } A$ is a Cartan subalgebra $\Rightarrow \Pi^{\mathfrak{g}, A}$ is regular, integrable and non-degenerate.

First note that if \mathfrak{g} is non-degenerate and $\text{Ker } A$ is a Cartan subalgebra, then $\text{ind } \mathfrak{g} = \text{corank } A$. Moreover, the central extension \mathfrak{g}_A is again non-degenerate and the kernel of the lift of A onto \mathfrak{g}_A is again a Cartan subalgebra. Therefore, $\text{ind } \mathfrak{g}_A = \text{corank } A$. But this implies regularity of $\Pi^{\mathfrak{g}, A}$ taking into account Proposition 2.1.2.

Now note that we do not need to prove integrability, because it automatically follows from non-degeneracy at the origin (which follows from the linear independence of the roots). Indeed, we can always find a regular point in the neighbourhood of a non-degenerate point. Due to analyticity regular points are everywhere dense, q.e.d.

5.3 Classification of non-degenerate linear pencils: the real case

It is possible to classify real non-degenerate linear pencils by classifying the real forms of complex non-degenerate algebras. However it seems to be better for the logic of the text to do it explicitly.

$\Pi^{\mathfrak{g},A}$ is non-degenerate $\Rightarrow \mathfrak{g}$ is non-degenerate and $\text{Ker } A$ is a **Cartan subalgebra**.

By Corollary 5.1.2 and Proposition 5.1.1 the subalgebra $\mathfrak{h} = \text{Ker } A$ is a Cartan subalgebra and the roots are linearly independent. These roots have the form $\pm\lambda_1, \dots, \pm\lambda_k, \pm\nu_1 i, \dots, \pm\nu_l i, \pm\mu_1 \pm \xi_1 i, \dots, \pm\mu_m \pm \xi_m i$. We can write

$$\mathfrak{g} = \mathfrak{h} + \langle e_{\pm 1}, \dots, e_{\pm k}, f_{\pm 1}, \dots, f_{\pm l}, g_{\pm 1}, h_{\pm 1}, \dots, g_{\pm m}, h_{\pm m} \rangle,$$

where

$$\begin{aligned} [x, e_i] &= \lambda_i(x)e_i \text{ for } x \in \mathfrak{h}, \\ [x, f_i] &= \nu_i(x)f_{-i} \text{ for } x \in \mathfrak{h}, \\ [x, g_i] &= \mu_i(x)g_i - \xi_i(x)h_i \text{ for } x \in \mathfrak{h}, \\ [x, h_i] &= \xi_i(x)g_i + \mu_i(x)h_i \text{ for } x \in \mathfrak{h}, \end{aligned}$$

where, by definition,

$$\begin{aligned} \lambda_{-i} &= -\lambda_i, \nu_{-i} = -\nu_i, \\ \mu_{-i} &= -\mu_i, \xi_{-i} = -\xi_i. \end{aligned}$$

It is easy to check that

$$\begin{aligned} [e_i, e_{-i}] &\in \mathfrak{h}, \\ [f_i, f_{-i}] &\in \mathfrak{h}, \\ [g_i, g_{-i}] &= -[h_i, h_{-i}] \in \mathfrak{h}, \\ [g_i, h_{-i}] &= [h_i, g_{-i}] \in \mathfrak{h}, \end{aligned}$$

and all other commutators vanish.

Suppose that $\lambda_i([e_i, e_{-i}]) \neq 0$ for some i . In this case the triple $e_i, e_{-i}, [e_i, e_{-i}]$ generate a subalgebra isomorphic to $\mathfrak{sl}(2, \mathbb{R})$. It can be shown that this subalgebra can be separated as a direct summand, analogous to the complex case.

Similarly, if $\nu_i([f_i, f_{-i}]) \neq 0$, we obtain a summand isomorphic to $\mathfrak{so}(3, \mathbb{R})$ if $\nu_i([f_i, f_{-i}]) > 0$ and $\mathfrak{sl}(2, \mathbb{R})$ if $\nu_i([f_i, f_{-i}]) < 0$.

Further, we have

$$\begin{aligned} \xi_i([g_i, g_{-i}])g_i + \mu_i([g_i, g_{-i}])h_i &= [[g_i, g_{-i}], h_i] = \\ &= -[[g_{-i}, h_i], g_i] = \mu_i([g_{-i}, h_i])g_i - \xi_i([g_{-i}, h_i])h_i, \end{aligned}$$

therefore

$$\begin{aligned} \xi_i([g_i, g_{-i}]) &= \mu_i([g_{-i}, h_i]), \\ \mu_i([g_i, g_{-i}]) &= -\xi_i([g_{-i}, h_i]), \end{aligned}$$

which means that ξ_i and ν_i are either linearly independent on the subspace $\langle [g_i, g_{-i}], [g_{-i}, h_i] \rangle$ or both vanish. In the first case the elements $g_i, g_{-i}, h_i, h_{-i}, [g_i, g_{-i}], [g_{-i}, h_i]$ generate a subalgebra isomorphic to $\mathfrak{so}(3, \mathbb{C})$.

After separating all described summands, we see that

$$\begin{aligned} [e_i, e_{-i}] &\in Z(\mathfrak{g}), \\ [f_i, f_{-i}] &\in Z(\mathfrak{g}), \\ [g_i, g_{-i}] &= -[h_i, h_{-i}] \in Z(\mathfrak{g}), \\ [g_i, h_{-i}] &= [h_i, g_{-i}] \in Z(\mathfrak{g}). \end{aligned}$$

In a way absolutely similar to the complex case it can be shown that \mathfrak{g} is decomposed into a sum of an abelian algebra and a quotient of a sum of several copies of $\mathfrak{g}_{\diamond}^h, \mathfrak{g}_{\diamond}, \mathfrak{g}_{\diamond}^{\mathbb{C}}$ by some central ideal.

\mathfrak{g} is non-degenerate and $\text{Ker } A$ is a Cartan subalgebra $\Rightarrow \Pi^{\mathfrak{g},A}$ is regular, integrable and non-degenerate.

The proof is similar to the complex case.

5.4 Proof of the second part of Theorem 6

In this section we will keep the notations of Section 5.3.

By Proposition 5.1.1 the type of $\text{Sing}(\Pi^{\mathfrak{g},A})$ is (k_e, k_h, k_f) , where k_e is the number of pairs of roots of type $\pm\nu_j i$, k_h is the number of pairs of type $\pm\lambda_j$, k_f is the number of quadruples of type $\pm\mu_j \pm \xi_j i$.

Now note that in the proof of Theorem 6 only complex roots gave rise to summands of type $\mathfrak{so}(3, \mathbb{C}), \mathfrak{g}_{\diamond}^{\mathbb{C}}$. This means that k_f indeed coincides with the number of summands of type $\mathfrak{so}(3, \mathbb{C}), \mathfrak{g}_{\diamond}^{\mathbb{C}}$.

For a pair of pure imaginary roots there are three possibilities:

1. $\nu_j([f_j, f_{-j}]) = 0 \Rightarrow \mathfrak{g}_{\diamond}$.
2. $\nu_j([f_j, f_{-j}]) < 0 \Rightarrow \mathfrak{sl}(2, \mathbb{R})$.
3. $\nu_j([f_j, f_{-j}]) > 0 \Rightarrow \mathfrak{so}(3, \mathbb{R})$.

Let us consider the second case and calculate the Killing form on the element $z = [f_j, f_{-j}]$. We have

$$\begin{aligned} [z, f_j] &= \nu_j(z) f_{-j}, \\ [z, f_{-j}] &= -\nu_j(z) f_j. \end{aligned}$$

The value of the Killing form on the element z is equal to

$$\text{tr}(\text{ad}z)^2 = -2\nu_j(z)^2 < 0.$$

Now let us consider the case of a pair of real roots. There are two possibilities:

1. $\lambda_j([e_j, e_{-j}]) = 0 \Rightarrow \mathfrak{g}_{\diamond}^h$.
2. $\lambda_j([e_j, e_{-j}]) \neq 0 \Rightarrow \mathfrak{sl}(2, \mathbb{R})$.

Consider the second case and calculate the Killing form on $z = [e_j, e_{-j}]$. We have

$$\begin{aligned} [z, e_j] &= \lambda_j(z)e_j, \\ [z, e_{-j}] &= -\lambda_j(z)e_{-j}. \end{aligned}$$

The value of the Killing form on z is

$$\mathrm{tr}(\mathrm{ad}z)^2 = 2\lambda_j(z)^2 > 0.$$

Therefore, the number k_e is equal to the number of summands of type \mathfrak{g}_{\diamond} + the number of summands of type $\mathfrak{so}(3, \mathbb{R})$ + the number of summands of type $\mathfrak{sl}(2, \mathbb{R})$ with a negative value of Killing form on the intersection $\mathfrak{sl}(2, \mathbb{R}) \cap \mathrm{Ker} A$, while the number k_h is equal to the number of summands of type $\mathfrak{g}_{\diamond}^h$ + the number of summands of type $\mathfrak{sl}(2, \mathbb{R})$ with a positive value of Killing form on the intersection $\mathfrak{sl}(2, \mathbb{R}) \cap \mathrm{Ker} A$. The theorem is proved.

5.5 Proof of the non-degeneracy criterion for arbitrary pencils

By Corollary 4.3.2, a singular point x is non-degenerate on a regular symplectic leaf of a bracket P_{α} if and only if the operators $D_f P_{\alpha}$, where $f \in \mathcal{F}$, $df \in \mathrm{Ker} P_{\alpha}$, generate a Cartan subalgebra in $\mathfrak{sp}(L^{\perp}/L, P_{\alpha})$. The type of the singular point coincides with the type of this subalgebra.

Proposition 5.5.1. *Suppose that a point x is non-degenerate. Then the pencil Π is diagonalizable at the point x .*

Proof. Indeed, since $D_f P_\alpha$ generate a Cartan subalgebra in $\mathfrak{sp}(L^\perp/L, P_\alpha)$, they should be diagonalizable. Moreover, we can find a linear combination of these operators, which have distinct eigenvalues. The recursion operator must commute with this linear combination (by Corollary 4.2.2). Therefore, the recursion operator must be diagonalizable. Now it suffices to apply Corollary 3.2.2. \square

In the diagonalizable situation the space L^\perp/L is decomposed, together with the form P_α , into the direct sum of the eigenspaces of the recursion operator (Corollary 3.2.1). These eigenspaces are invariant with respect to the operators $D_f P_\alpha$ (Corollary 4.2.3).

Proposition 5.5.2. *Let Π be a pencil diagonalizable at point x . Then the singular point x is non-degenerate on a regular symplectic leaf of bracket P_α if and only if for each $\lambda \in \Lambda(x)$ the set of operators $D_f P_\alpha$ generate a Cartan subalgebra in*

$$\mathfrak{sp}(\operatorname{Re} \operatorname{Ker} (P_\lambda |_{\mathbb{C} \otimes L^\perp/L}), P_\alpha).$$

The type of x is the sum of types of these Cartan subalgebras.

Proof. By Corollary 3.2.1, the space L^\perp/L is decomposed into the sum of real parts of the eigenspaces of the recursion operator. In other words,

$$L^\perp/L = \bigoplus_{\lambda \in \mathbb{R} \cap \Lambda(x)} \operatorname{Ker} (P_\lambda |_{L^\perp/L}) \oplus \bigoplus_{\substack{\lambda \in \Lambda(x), \\ \operatorname{Im} \lambda > 0}} \operatorname{Re} \operatorname{Ker} (P_\lambda |_{\mathbb{C} \otimes L^\perp/L})$$

The summands of this decomposition are pairwise orthogonal with respect to all brackets of the pencil. Consequently,

$$\begin{aligned} \mathfrak{sp}(L^\perp/L, P_\alpha) &= \bigoplus_{\lambda \in \mathbb{R} \cap \Lambda(x)} \mathfrak{sp}(\operatorname{Ker} (P_\lambda |_{L^\perp/L}), P_\alpha) \oplus \\ &\oplus \bigoplus_{\substack{\lambda \in \Lambda(x), \\ \operatorname{Im} \lambda > 0}} \mathfrak{sp}(\operatorname{Re} \operatorname{Ker} (P_\lambda |_{\mathbb{C} \otimes L^\perp/L}), P_\alpha). \end{aligned}$$

Now it suffices to apply Corollary 4.3.2 and Corollary 4.2.4. \square

Proposition 5.5.3. *Let Π be a pencil diagonalizable at x . Let $\mathbb{K} = \mathbb{R}$ if λ is real and \mathbb{C} otherwise. Then the set of operators $D_f P_\alpha$ generate a Cartan subalgebra in $\mathfrak{sp}(\text{Ker}(P_\lambda |_{\mathbb{K} \otimes L^\perp / L}), P_\alpha)$ if and only if the pencil $d_\lambda \Pi(x)$ is non-degenerate. The type of this subalgebra for real λ coincides with the type of $\text{Sing}(d_\lambda \Pi(x))$.*

Proof. By Proposition 4.2.3

$$\{D_f P_\alpha |_{\text{Ker } P_\lambda}, f \in \mathcal{F}, df \in \text{Ker } P_\alpha\} = \{\text{ad}_\xi, \xi \in \mathfrak{g}_\lambda \cap \mathbb{K} \otimes L\}.$$

In the diagonalizable case we have $\mathfrak{g}_\lambda \cap \mathbb{K} \otimes L = \text{Ker}(P_\alpha |_{\mathfrak{g}_\lambda})$.

But

$$\mathfrak{h} = \{\text{ad}_\xi, \xi \in \text{Ker}(P_\alpha |_{\mathfrak{g}_\lambda})\}$$

is a Cartan subalgebra in $\mathfrak{sp}(\mathfrak{g}_\lambda / \mathfrak{h})$ if and only if the pencil $d_\lambda \Pi(x)$ is non-degenerate (Proposition 5.1.1). The type of this subalgebra coincides with the type of $\text{Sing}(d_\lambda \Pi(x))$ by the same Proposition 5.1.1. \square

Proposition 5.5.4. *For a complex value of λ the set of operators $D_f P_\alpha$ generate a Cartan subalgebra in $\mathfrak{sp}(\text{Re Ker}(P_\lambda |_{\mathbb{C} \otimes L^\perp / L}), P_\alpha)$ if and only if the pencil $d_\lambda \Pi(x)$ is non-degenerate. The type of this subalgebra is $(0, 0, k_f)$, where k_f equals half of its dimension.*

Proof. Let the pencil $d_\lambda \Pi(x)$ be non-degenerate. Then the pencil $d_{\bar{\lambda}} \Pi(x)$ is also non-degenerate. But this means that the set of operators $D_f P_\alpha$ generate a Cartan subalgebra in

$$\mathfrak{sp}(\text{Ker}(P_\lambda |_{\mathbb{C} \otimes L^\perp / L}) \oplus \text{Ker}(P_{\bar{\lambda}} |_{\mathbb{C} \otimes L^\perp / L}), P_\alpha).$$

Now note that

$$(\text{Ker}(P_\lambda |_{\mathbb{C} \otimes L^\perp / L}) \oplus \text{Ker}(P_{\bar{\lambda}} |_{\mathbb{C} \otimes L^\perp / L})) \cap (L^\perp / L) = \text{Re Ker}(P_\lambda |_{\mathbb{C} \otimes L^\perp / L}).$$

Therefore operators $D_f P_\alpha$ generate a Cartan subalgebra in $\mathfrak{sp}(\operatorname{Re} \operatorname{Ker}(P_\lambda|_{\mathbb{C} \otimes L^\perp/L}), P_\alpha)$ as well (taking into account that these operators are real). The inverse statement is proved analogously.

To prove the statement about the type note that if $D_f P_\alpha$ has pure imaginary or real eigenvalue on $\operatorname{Re} \operatorname{Ker}(P_\lambda|_{\mathbb{C} \otimes L^\perp/L})$, then ad_ξ in \mathfrak{g}_λ has the same eigenvalue. But a generic element in Cartan subalgebra of $\mathfrak{sp}(2n, \mathbb{C})$ doesn't have such eigenvalues. \square

Proof of Theorem 8. We have already shown that it is a necessary for a pencil to be diagonalizable. Therefore it suffices to show that for a diagonalizable pencil x is non-degenerate if and only if for each $\lambda \in \Lambda(x)$ the linear pencil $d_\lambda \Pi(x)$ is non-degenerate. But taking into account Propositions 5.5.3, 5.5.4, our statement directly follows from Proposition 5.5.2. \square

Proof of Theorem 9. Taking into account Propositions 5.5.3, 5.5.4, our statement directly follows from Proposition 5.5.2. \square

Chapter 6

Multidimensional rigid body

6.1 Introduction

Speaking informally, free multidimensional rigid body is simply a rigid body rotating in multidimensional space without action of any external forces (i.e. by inertia).

Let us first discuss three-dimensional free rigid body (the so-called Euler case in the rigid body dynamics). A good model for such a body is a book or a parallelepiped shaped box.

Now throw the book in the air spinning it in arbitrary direction. If we neglect the gravity force, then what we get is exactly the Euler case.

Note that a general trajectory of a body is not a rotation in a usual sense. At each moment of time our body is indeed rotating around some axis, but this axis is changing as time goes. What we are interested in, are the relative equilibria of the system, i.e. such trajectories for which the axis of rotation remains fixed. Such rotations are also called stationary.

It is well known that a generic three-dimensional rigid body (i.e. a body with pairwise distinct principal moments of inertia) admits three stationary

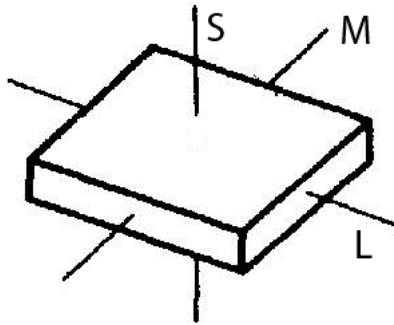

Figure 6.1: Three-dimensional rigid body. Letters S,M,L stand for the small, middle and large axes of symmetry respectively.

rotations: these are the rotations around three principal axes of inertia. If we deal with a parallelepiped shaped body, then these axes coincide with three axes of symmetry (see fig. 6.1).

Now spin our body around one of these axes. Of course, since our hands and eyes are not too precise, we will have a small mistake in the initial data. But this is not going to be fatal if we spin the body around the shortest or the longest axis. We will not have a stationary rotation, but something very close to it. This is due to the fact that *the rotations of a free three-dimensional rigid body around the shortest and the longest principal axes of inertia are (Lyapunov) stable*. But if we rotate around the middle axis, we will see something essentially different: the axis of rotation will start changing rapidly and the body will start rotating in other direction. This is because *the rotation of a free three-dimensional rigid body around the middle principal axis of inertia is (Lyapunov) unstable*.

Basically, what we are interested in, is to generalise this result to the case of multidimensional body. The equations of multidimensional free rigid body in modern literature were first written by Arnold (see his book [2], however, these equations were already known to Schottky and Frahm).

In matrix representation Arnold equations look the same as Euler equations for a three-dimensional body. But we shall emphasise that Arnold equations are not just Euler equations generalised to the multidimensional case, but the equations which describe a real mechanical object: a multidimensional rigid body. And this object (but not just the equations!) is what we want to study.

First we shall discuss how an n -dimensional body may rotate. At each moment of time \mathbb{R}^n is decomposed into the sum of m pairwise orthogonal two-dimensional planes Π_1, \dots, Π_m and an $n - 2m$ -dimensional space Π_0 , orthogonal to all these planes:

$$\mathbb{R}^n = \left(\bigoplus_{i=1}^m \Pi_i \right) \oplus \Pi_0.$$

There is an independent rotation in each of the planes Π_1, \dots, Π_m , while Π_0 is fixed. This is just a reformulation of the theorem about canonical form of a skew-symmetric operator. Note that Π_0 may be zero in the even-dimensional case, which means that there are no fixed axes.

A rotation is stationary if all planes Π_0, \dots, Π_m don't change with time (this condition automatically implies that the velocities of rotations are also constant). It is known that a rotation of a generic multidimensional rigid body is stationary if and only if the corresponding planes are spanned by main axes of inertia (provided that the angular velocities of rotations in different planes are pairwise distinct¹, see [14, 4]). We wonder which of these rotations are stable and which are not.

In four dimensions the problem was studied from different points of view by Oshemkov (see [32]), Feher and Marshall (see [14]), Petre Birtea, Ioan Caşu, Tudor S. Ratiu, and Murat Turhan (see [4]), Petre Birtea and Ioan

¹Some authors omit this condition, however it is crucial, see section 6.3 of this thesis.

Caşu (see [3]). The answer is known for a dense subset of relative equilibria.

The five-dimensional case was studied by Caşu in [9]. The set of equilibria which were studied in this case is not dense.

General even-dimensional rigid body was discussed in Spiegler's PhD thesis [37]. A sufficient condition for an equilibrium to be stable is found.

A. Spiegler approached the problem using the so-called Arnold's energy-Casimir method (see [1, 34]). The main idea of this method is the following:

Suppose we have a system which is hamiltonian on some Poisson manifold. Let x be an equilibrium of the system. Then x is a critical point for the Hamiltonian restricted to the symplectic leaf passing through x . If it turns out that this point is non-degenerate maximum or minimum, then x is a stable equilibrium, provided that the corresponding symplectic leaf is regular.

The Energy-Casimir method is a very powerful tool for studying equilibria of general Hamiltonian systems. But if our system possesses some additional symmetries (for example, it is completely integrable), there are more simple and efficient ways to study stability. One may see, comparing the result of A. Spiegler with our results, that there is an open subset in the set of stable equilibria for which the hamiltonian is *not* positive definite. Therefore, for this equilibria the energy-Casimir method doesn't work.

As it was shown by Manakov in his paper [27], our system is completely integrable². Therefore we may apply methods developed in the theory of

²More precisely, Manakov has shown that the system admits an $L - A$ pair with a spectral parameter. This allowed him to write down integrals and to show that the system is integrable in θ -functions of Riemannian surfaces. However, Manakov didn't prove that his integrals are enough for Liouville integrability. Complete integrability in the Liouville sense was proved in [30]. See also earlier paper [29], where Mischenko found the quadratic integrals of the problem. These integrals are enough for complete integrability in the four-dimensional case.

integrable hamiltonian systems. For example, if we know that an equilibrium point is non-degenerate and know its type, then the stability problem is easily solved. The four-dimensional case from the integrable point of view was studied in [32]. The integrable approach is very effective, but still involves heavy calculations if the dimension is larger than four. However, instead of explicit calculations with the integrals, we can use the fact that the system possesses a bihamiltonian structure.

The bihamiltonian structure for the multidimensional rigid body equations which we are going to use was discovered by A.Bolsinov in [5] (see also [6, 31]). This structure is defined on the dual space of the Lie algebra of skew-symmetric matrices³.

The bihamiltonian approach for studying the singularities of multidimensional rigid body was applied in [8]. In this paper Bolsinov and Oshemkov obtain a sufficient condition for non-degeneracy of zero-rank singularities. Developing their ideas and applying the constructions of the first part of the present thesis, we manage to solve the stability problem for almost all relative equilibria. Moreover, we give a non-degeneracy criteria for an equilibrium point and describe type of non-degenerate points, which makes it possible to give a complete description of the behaviour of the system in a neighbourhood of an equilibrium.

The answers we get are simple and geometric.

³However, it is possible to give another bihamiltonian formulation: the bihamiltonian structure is defined on the dual of $\mathfrak{sl}(n)^*$ and then our system is obtained by restriction from $\mathfrak{sl}(n)^*$ to $\mathfrak{so}(n)^*$. This structure (in different terminology) is present in the paper [30]. See also [35].

6.2 The equations

Motion of multidimensional rigid body is described by the Euler-Arnold equations on $\mathfrak{so}(n)^*$ (identified with $\mathfrak{so}(n)$). These equations have the form

$$\begin{cases} \dot{M} &= [M, \Omega] \\ M &= \Omega J + J\Omega, \end{cases} \quad (6.1)$$

where

- $M \in \mathfrak{so}(n)^*$ is a skew-symmetric matrix, called the angular momentum matrix.
- J is a symmetric matrix, called the mass tensor of the rigid body.
- Ω is a skew-symmetric matrix, called the angular velocity matrix. It is uniquely defined by the relation

$$M = \Omega J + J\Omega.$$

Remark 6.2.1. Since the map $\mathcal{J}: \mathfrak{so}(n) \rightarrow \mathfrak{so}(n)$ given by the formula

$$\mathcal{J}(\Omega) = \Omega J + J\Omega$$

is invertible, our equations can be rewritten in the Ω -coordinates:

$$\dot{\Omega} = \mathcal{J}^{-1}([\mathcal{J}(\Omega), \Omega]).$$

However, the explicit formula for \mathcal{J}^{-1} is quite complicated, therefore it is convenient to introduce the variable M and write down the equations in the form (6.1).

Note that the equations (6.1) are only equations on angular velocities of the body. If we want to recover the dynamics in the configuration space, we should add Poisson equations

$$\dot{X} = X\Omega.$$

However, we will only be interested in reduced dynamics, given by equations (6.1). Note that relative equilibria of the rigid body is nothing else but the equilibrium points of the system (6.1).

6.3 Description of relative equilibria

Theorem 11. *Consider the system of Euler-Arnold equations*

$$\begin{cases} \dot{M} &= [M, \Omega] \\ M &= \Omega J + J\Omega. \end{cases}$$

Suppose that J has pairwise distinct eigenvalues. Then M is an equilibrium point of the system if and only if there exists an orthonormal basis such that J is diagonal, and Ω is block-diagonal of the following form

$$\begin{pmatrix} \nu_1 A_1 & 0 & 0 \\ 0 & \ddots & 0 \\ 0 & 0 & \nu_k A_k \end{pmatrix}, \quad (6.2)$$

where $A_i \in \mathfrak{so} \cap \text{SO}$ and ν_i are arbitrary real numbers.

Remark 6.3.1. Relative equilibria of Euler-Arnold equations was studied by many authors, however we could not find the final answer given by this theorem in the literature.

Proof. We have

$$[M, \Omega] = [\Omega J + J\Omega, \Omega] = [J, \Omega^2],$$

therefore M is an equilibrium if and only if Ω^2 commutes with J .

Assume we have a basis such that J is diagonal and Ω has the form (6.2).

Then

$$A_i^2 = -A_i A_i^\dagger = -E$$

and

$$\Omega^2 = \begin{pmatrix} -\nu_1^2 E & 0 & 0 \\ 0 & \ddots & 0 \\ 0 & 0 & -\nu_k^2 E \end{pmatrix}.$$

Therefore, $[\Omega^2, J] = 0$, and our point is an equilibrium point.

Now, let $[\Omega^2, J] = 0$. We shall prove that there exists a basis such that J is diagonal and Ω has the form (6.2).

First find an orthonormal basis such that J is diagonal. Ω^2 is diagonal in this basis as well, since J has pairwise distinct eigenvalues. By permutation of basis vectors bring Ω^2 to the form

$$\begin{pmatrix} -\nu_1^2 E & 0 & 0 \\ 0 & \ddots & 0 \\ 0 & 0 & -\nu_k^2 E \end{pmatrix},$$

where all ν_i are pairwise distinct.

Note that eigenspaces of Ω^2 are orthogonal with respect to Ω . Indeed, let $\Omega^2 x = -\nu_i^2 x$, $\Omega^2 y = -\nu_j^2 y$, and $\nu_j \neq 0$. Then

$$\langle \Omega x, y \rangle = -\frac{1}{\nu_j^2} \langle \Omega x, \Omega^2 y \rangle = \frac{1}{\nu_j^2} \langle \Omega^2 x, \Omega y \rangle = -\frac{\nu_i^2}{\nu_j^2} \langle x, \Omega y \rangle = \frac{\nu_i^2}{\nu_j^2} \langle \Omega x, y \rangle.$$

Since $\nu_i \neq \nu_j$, we have $\langle \Omega x, y \rangle = 0$.

Consequently, in our basis Ω has the form

$$\begin{pmatrix} B_1 & 0 & 0 \\ 0 & \ddots & 0 \\ 0 & 0 & B_k \end{pmatrix},$$

where $B_i^2 = -\nu_i^2 E$.

We need to prove that $B_i = \nu_i A_i$, where $A_i \in \mathfrak{so} \cap \text{SO}$. If $\nu_i = 0$, everything is proved. If not, set

$$A_i = \frac{1}{\nu_i} B_i.$$

On one hand, $A_i \in \mathfrak{so}$. On the other hand

$$A_i A_i^t = -A_i^2 = -\frac{1}{\nu_i^2} B_i^2 = E,$$

which means that $A_i \in \text{SO}$, q.e.d. □

Remark 6.3.2. Note that $\mathfrak{so}(2m) \cap \text{SO}(2m)$ is the homogeneous space $\text{O}(2m)/\text{U}(m)$ which is identified with the space of complex structures compatible with the standard euclidian metrics.

Corollary 6.3.1. *Suppose that M is a relative equilibrium, all eigenvalues of J are pairwise distinct. Moreover, let all eigenvalues of Ω (eigenfrequencies of rotation) be pairwise distinct. Then there exists an orthonormal basis such that J is diagonal, while Ω and M are block-diagonal with two-by-two blocks on the diagonal.*

In other words, stationary rotation with pairwise distinct eigenfrequencies is rotation in main axes of inertia.

Definition 18. We will say that an equilibrium M is *regular* if there exists an orthonormal basis such that J is diagonal and Ω is block-diagonal with two-by-two blocks on the diagonal (i.e. M is rotation in main axes of inertia). Otherwise, we will say that M is *exotic*.

Corollary 6.3.1 says that all stationary rotations with pairwise distinct eigenfrequencies are regular.

We will see later that regular equilibria are exactly rank zero singular points of the system in the sense of integrable systems theory, which means that these points are critical points for *all* integrals. Exotic equilibria are, on the contrary, non-zero rank singular points, which means that there exists an integral the differential of which doesn't vanish in the equilibrium point. This implies that exotic equilibria are not isolated on the orbits of $\mathfrak{so}(n)$

bracket, but form whole smooth submanifolds of equilibrium points, while regular equilibria are always isolated (on a coadjoint orbit).

We will also show that exotic equilibria are always unstable.

6.4 Parabolic diagram of a regular relative equilibrium

Let M be a regular relative equilibrium. Then there exists an orthonormal basis such that J is diagonal and Ω is block-diagonal with two-by-two blocks on the diagonal. In other words, there exists a decomposition

$$\mathbb{R}^n = \left(\bigoplus_{i=1}^m \Pi_i \right) \oplus \Pi_0, \quad (6.3)$$

where

- Each $\Pi_i, i > 0$ is spanned by two main axes of inertia. There is a rotation in each of these planes with angular velocity ω_i .
- Π_0 is spanned by $n - 2m$ axes of inertia and is fixed.

Therefore, to define a regular relative equilibrium, we need to choose an integer m such that $0 \leq m \leq [n/2]$ and pick m pairs out of the set of principal axes of inertia. For each pair we need to define angular velocity. Choice of pairs and values of angular velocities uniquely define a regular relative equilibrium. Knowing this data, we want to understand whether an equilibrium is stable or not.

We are going to define an object called *the parabolic diagram* of a relative equilibria of a multidimensional rigid body. This object will allow us to express stability conditions in geometric terms. For each plane $\Pi_i, i > 0$ let us

denote the corresponding eigenvalues of the mass tensor J by $\lambda_1(\Pi_i), \lambda_2(\Pi_i)$ and the corresponding angular velocity by $\omega(\Pi_i)$.

Definition 19. *The parabolic diagram* of a relative equilibrium is the following set of parabolas and vertical lines drawn on the same coordinate plane:

- For each Π_i draw a parabola given by

$$\chi_i(x) = \frac{(x - \lambda_1(\Pi_i))^2(x - \lambda_2(\Pi_i))^2}{\omega(\Pi_i)^2(\lambda_1(\Pi_i) + \lambda_2(\Pi_i))^2}.$$

- For all fixed axes draw vertical lines through the squares of corresponding eigenvalues.

Remark 6.4.1. Each χ_i is a quadratic function the roots of which are squares of the eigenvalues of J . Therefore what we do is we simply draw parabolas through the squares of eigenvalues corresponding to moving axes and vertical lines through the squares of eigenvalues corresponding to fixed axes.

Remark 6.4.2. The leading coefficient of χ_i is inverse proportional to the square of the angular momentum $m(\Pi_i) = \omega(\Pi_i)(\lambda_1(\Pi_i) + \lambda_2(\Pi_i))$.

Let us accept the following formal agreement:

- Two parabolas intersect at infinity, if their leading coefficients are equal and non-zero, i.e. if they have only one point of intersection (of multiplicity one).
- Two parabolas are tangent at infinity if they can be obtained from each other by a vertical shift, i.e. have no points of intersection (real or complex).

Definition 20. We will say that a parabolic diagram is generic if all intersections on it are simple, i.e. it contains no multiple intersections and no points of tangency.

6.5 Stability theorems

Theorem 12. *Let M be a regular equilibrium. Suppose that*

- *M has no more than two fixed axes ($\dim \Pi_0 \leq 2$).*
- *The parabolic diagram of M is generic.*
- *All intersections on the parabolic diagram are either real and belong to the upper half-plane or infinite.*

Then M is stable.

Theorem 13. *Let M be a regular equilibrium. Suppose that*

- *M has no more than two fixed axes ($\dim \Pi_0 \leq 2$).*
- *There is at least one intersection on the parabolic diagram of M which is either complex or belong to the lower half-plane.*

Then M is unstable.

Theorem 14. *Let M be an exotic equilibrium. Then M is unstable.*

Question 1. *Can we omit the condition $\dim \Pi_0 \leq 2$ in Theorems 12, 13⁴?*

Question 2. *Can we omit the condition that the parabolic diagram is generic in Theorem 12?*

Whether or not the answer to these questions is positive, Theorems 12, 13, 14 are already enough to solve the stability problem for an open dense

⁴The problem is that if $\dim \Pi_0 > 2$, then $M \in \text{Bad}$ in terms of the first part of this thesis (i.e. the rank of all brackets of the pencil drops at M) and we don't know how to work with such points. However, it is quite natural to consider rotations with lots of fixed axes. The answer to the question is probably positive.

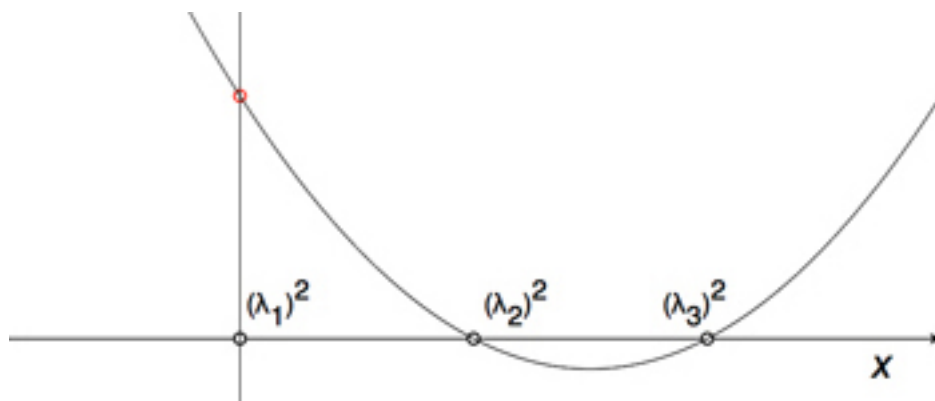

Figure 6.2: Rotation of a 3d-body around the shortest principal axis of inertia. The intersection point is above the X axis \Rightarrow stable

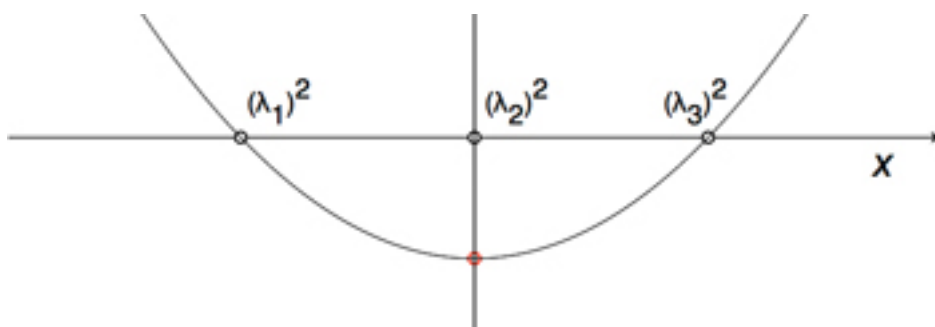

Figure 6.3: Rotation of a 3d-body around the middle principal axis of inertia. The intersection point is below the X axis \Rightarrow unstable

subset of relative equilibria. Proof of these three theorems can be found in Section 6.18.

Now we shall discuss some examples. First let us recover the classical three-dimensional result.

Example 6.5.1 (Three-dimensional body). Parabolic diagrams for a 3-dimensional body are illustrated on figures 6.2, 6.3, 6.4. We see from the parabolic diagrams that the rotation around the middle axis is unstable, while the rotations about the shortest and the longest axes are stable.

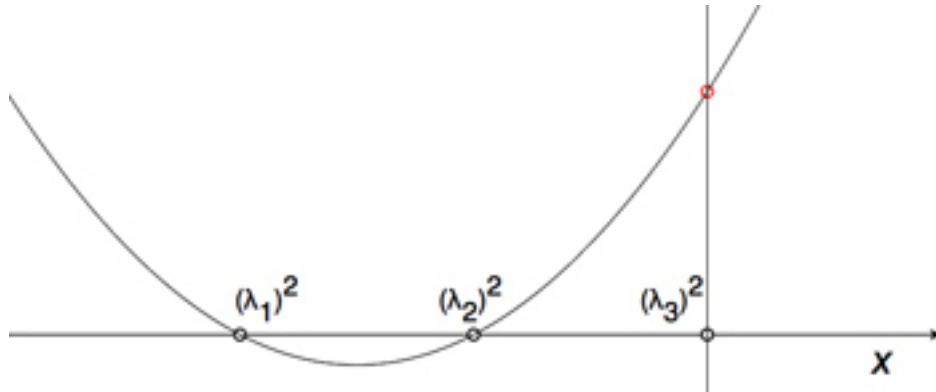

Figure 6.4: Rotation of a 3d-body around the longest principal axis of inertia. The intersection point is above the X axis \Rightarrow stable

Example 6.5.2 (Four-dimensional body). There are three different cases:

1. The first plane is spanned by two short axes of inertia, the second plane is spanned by two long axes of inertia. We look at the parabolic diagram (see figure 6.5) and see that the rotation is stable.
2. The first plane is spanned by the shortest and the second longest axes, the second plane is spanned by the longest and the third shortest axes. We look at the parabolic diagram (see figure 6.6) and see that the rotation is unstable.
3. The first plane is spanned by the longest and the shortest axes, and the second plane is spanned by two middle axes. See figures 6.7, 6.8, 6.9, 6.10, 6.11. We see that everything depends on the ratio of angular velocities here. If the rotation in the “inner” (i.e. spanned by the middle axes) plane is fast enough, we have stability. If it is slow, we have instability.

The situation is similar to the rotation of a 3d body with a gyroscope inside around the middle axis of inertia. If the gyroscope is rotating

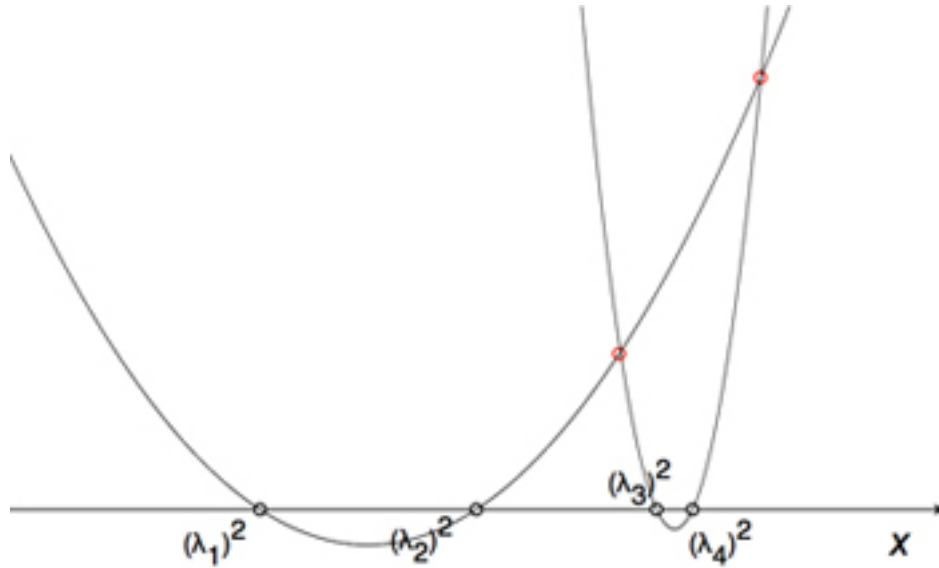

Figure 6.5: Rotation of a 4d-body. Parabolic diagram is generic, all intersection points are above the X axis \Rightarrow stable

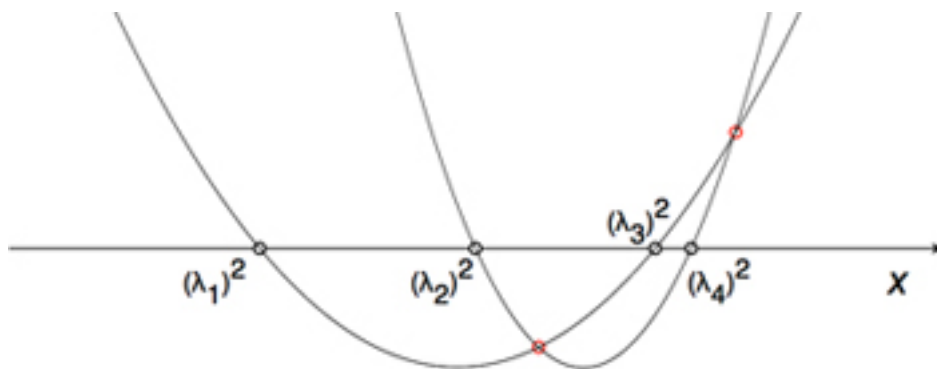

Figure 6.6: Rotation of a 4d-body. One intersection point is above the X axis, second is below \Rightarrow unstable

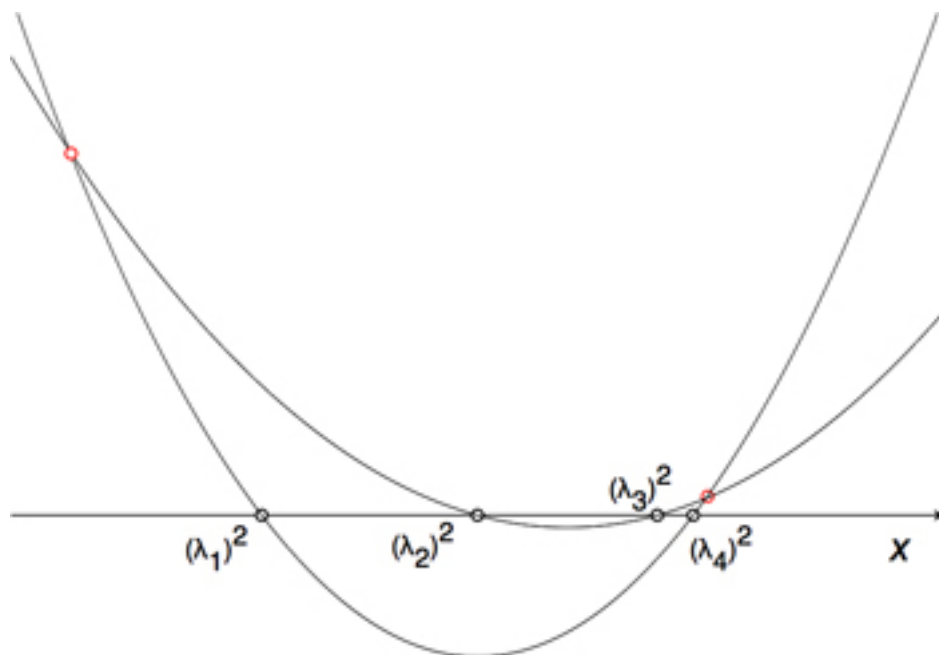

Figure 6.7: Rotation of a 4d-body. Parabolic diagram is generic, all intersection points are above the X axis \Rightarrow stable

fast enough, it stabilises the rotation of the body. The “inner” plane in a four-dimensional body plays the role of a gyroscope.

In the non-generic case illustrated on figure 6.10 our theorems do not give an answer. However, it is possible to show that the corresponding rotation is stable (and admits a Lyapunov function of degree four). This implies that stability loss in four-dimensional body is always “soft”, i.e. the set of stable equilibria is closed.

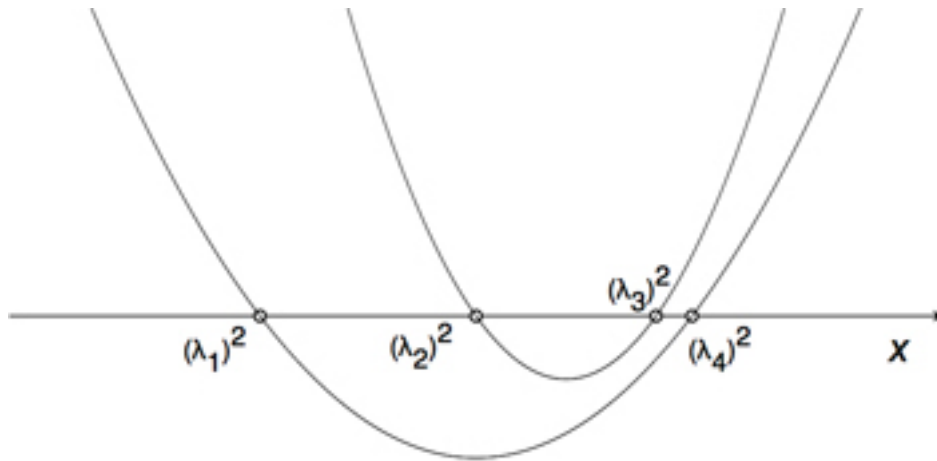

Figure 6.8: Rotation of a 4d-body. All intersection points are complex \Rightarrow unstable

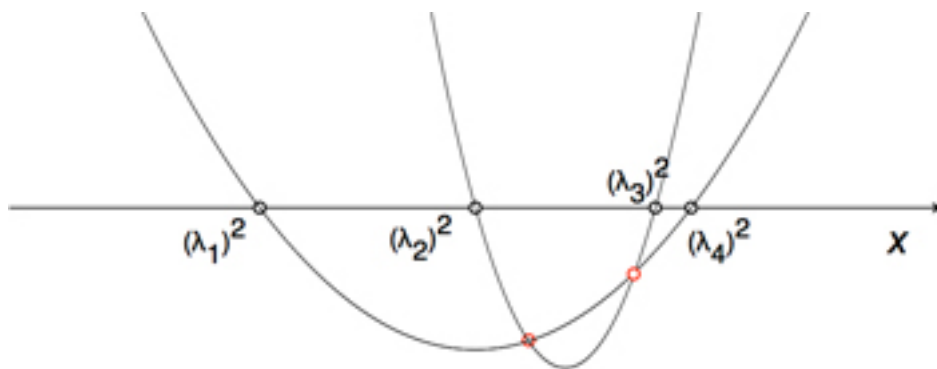

Figure 6.9: Rotation of a 4d-body. All intersection points are below the X axis \Rightarrow stable

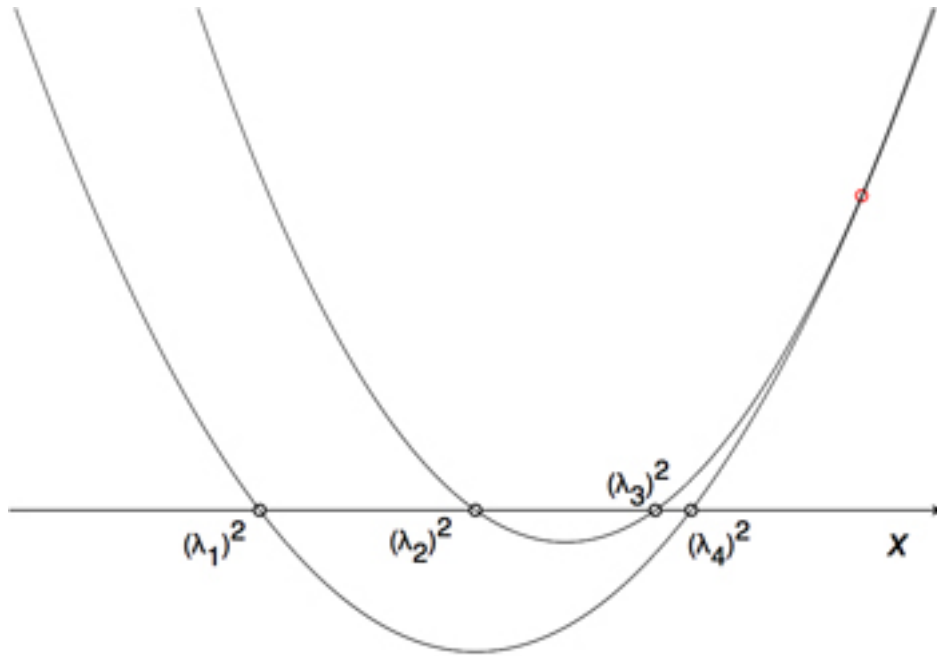

Figure 6.10: Rotation of a 4d-body. Parabolic diagram is not generic, all intersections point are above the X axis \Rightarrow we don't know!

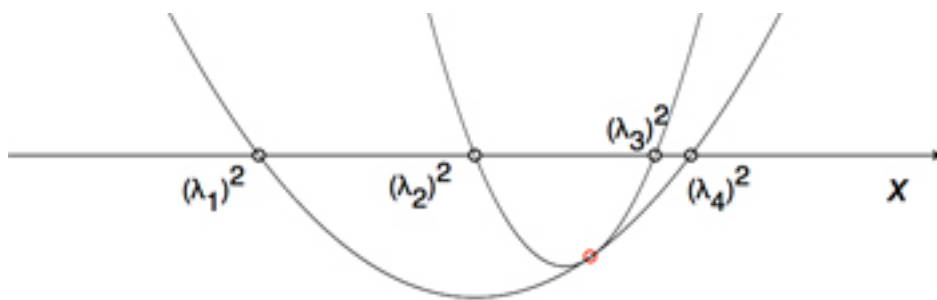

Figure 6.11: Rotation of a 4d-body. Parabolic diagram is not generic, but there is an intersection point below the X axis \Rightarrow unstable

6.6 The bihamiltonian structure

We will denote the Lie-Poisson bracket on $\mathfrak{so}(n)^*$ by $\{, \}_\infty$. It is given by

$$\{f, g\}_\infty(M) = \langle M, [df, dg] \rangle, \text{ where } M \in \mathfrak{so}(n)^*.$$

Proposition 6.6.1. *The equations (6.1) are hamiltonian with respect to the Lie-Poisson bracket on $\mathfrak{so}(n)^*$ with the hamiltonian given by the kinetic energy*

$$H = \frac{1}{2} \langle \Omega, M \rangle$$

Proof. Consider arbitrary function f . The derivative of f with respect to the equations will be

$$\langle df, [M, \Omega] \rangle = \langle M, [\Omega, df] \rangle = \langle M, [dH, df] \rangle = \{H, f\},$$

q.e.d.

□

Now we introduce a second operation on $\mathfrak{so}(n)$ defined by

$$[X, Y]_{J^2} = XJ^2Y - YJ^2X.$$

Proposition 6.6.2. *$[\cdot, \cdot]_{J^2}$ is a Lie bracket compatible with the standard Lie bracket. In other words, any linear combinations of these brackets define a Lie algebra structure on $\mathfrak{so}(n)$.*

Proof. It suffices to show that all operations on $\mathfrak{so}(n)$ having the form

$$[X, Y]_A = XAY - YAX$$

are Lie brackets, i.e. they satisfy the Jacobi identity. But this is just a straightforward computation. □

Now introduce an operation $\{, \}_0$ on $\mathfrak{so}(n)^*$ given by

$$\{f, g\}_0 = \langle M, (df)J^2(dg) - (dg)J^2(df) \rangle.$$

This is a Lie-Poisson brackets associated with the Lie bracket $[,]_{J^2}$. Proposition 6.6.2 implies the following

Proposition 6.6.3. $\{, \}_0$ is a Poisson bracket compatible with the Lie-Poisson bracket.

We will write down the corresponding pencil in the form

$$\{f, g\}_\lambda = \{f, g\}_0 - \lambda\{f, g\}_\infty = \langle M, df(J^2 - \lambda E)dg - dg(J^2 - \lambda E)df \rangle.$$

Theorem 15 (A.Bolsinov, [5, 6]). *The system (6.1) is Hamiltonian with respect to any bracket $\{, \}_\lambda$, i.e. it is bihamiltonian. The hamiltonian is given by*

$$H_\lambda = -\frac{1}{2} \langle (J + \sqrt{\lambda}E)^{-1} \Omega (J + \sqrt{\lambda}E)^{-1}, M \rangle.$$

Remark 6.6.1. Since J is positive-definite, the matrix $J + \sqrt{\lambda}E$ is invertible for any λ .

Proof. Let us write down the condition that a system is hamiltonian with respect to $\{, \}_\lambda$. Let H_λ be the corresponding hamiltonian and f be an arbitrary function. Then

$$\begin{aligned} \frac{df}{dt} &= \{H_\lambda, f\}_\lambda = \langle M, dH_\lambda(J^2 - \lambda E)df - df(J^2 - \lambda E)dH_\lambda \rangle = \\ &= \langle df, MdH_\lambda(J^2 - \lambda E) - (J^2 - \lambda E)dH_\lambda M \rangle, \end{aligned}$$

where df/dt is the derivative with respect to our system. On the other hand,

$$\frac{df}{dt} = \langle df, \dot{M} \rangle,$$

therefore

$$\dot{M} = M dH_\lambda(J^2 - \lambda E) - (J^2 - \lambda E) dH_\lambda M.$$

But we know that

$$\dot{M} = [\Omega J + J\Omega, \Omega] = J\Omega^2 - \Omega^2 J.$$

Consequently, we get an equation on H_λ of the form

$$(\Omega J + J\Omega) dH_\lambda(J^2 - \lambda E) - (J^2 - \lambda E) dH_\lambda(\Omega J + J\Omega) = J\Omega^2 - \Omega^2 J.$$

Denote $X = dH_\lambda, \nu = \sqrt{\lambda}$. Now our equation can be rewritten as

$$\begin{aligned} J\Omega^2 - \Omega^2 J &= (\Omega(J + \nu E) + (J - \nu E)\Omega)X(J + \nu E)(J - \nu E) - \\ &\quad - (J - \nu E)(J + \nu E)X(\Omega(J - \nu E) + (J + \nu E)\Omega) = \\ &= \Omega(J + \nu E)X(J + \nu E)(J - \nu E) - (J - \nu E)(J + \nu E)X(J + \nu E)\Omega + \\ &\quad + (J - \nu E)(\Omega X(J + \nu E) - (J + \nu E)X\Omega)(J - \nu E) \end{aligned}$$

Now denote

$$Y = (J + \nu E)X(J + \nu E).$$

We have

$$\begin{aligned} J\Omega^2 - \Omega^2 J &= \Omega Y(J - \nu E) - (J - \nu E)Y\Omega + \\ &\quad + (J - \nu E)(\Omega(J + \nu E)^{-1}Y - Y(J + \nu E)^{-1}\Omega)(J - \nu E) \end{aligned}$$

Obvoiusly, $Y = -\Omega$ is a solution. Therefore,

$$dH_\lambda = -(J + \nu E)^{-1}\Omega(J + \nu E)^{-1} \quad (6.4)$$

and

$$H_\lambda = -\frac{1}{2}\langle (J + \sqrt{\lambda}E)^{-1}\Omega(J + \sqrt{\lambda}E)^{-1}, M \rangle,$$

q.e.d. □

Remark 6.6.2. Note that for negative λ this function H_λ is complex. If we want a real hamiltonian, we must take the real part of H_λ (while the complex part is a Casimir function).

6.7 Notations

Let us fix the notations which will be used throughout the whole chapter.

We'll mainly discuss regular equilibria (except for the theorem 14). Therefore, we may always assume that there exists an orthonormal basis such that J is diagonal, while Ω and M are block-diagonal with two-by-two blocks on the diagonal.

Let us denote by λ_i the diagonal elements of J *in this basis*. Note that this means that λ_i are possibly different for different equilibria. However, they are unique up to permutation and coincide with the eigenvalues of J .

By ω_i we will denote the non-zero entries of matrix Ω , i.e.

$$\Omega = \begin{pmatrix} 0 & \omega_1 & & & & & & & \\ -\omega_1 & 0 & & & & & & & \\ & & \ddots & & & & & & \\ & & & & 0 & \omega_m & & & \\ & & & & -\omega_m & 0 & & & \\ & & & & & & 0 & & \\ & & & & & & & \ddots & \\ & & & & & & & & 0 \end{pmatrix}$$

By $m_i = (\lambda_{2i-1} + \lambda_{2i})\omega_i$ we will denote the entries of the matrix M .

n will always stand for the dimension of a body, m - for the number of non-zero ω_i 's (i.e. for the number of two-dimensional planes in the decomposition (6.3)).

6.8 The bad set

Since we know that our system is bihamiltonian, we may apply the construction discussed in the first part of the thesis. According to this construction, the first thing we should do is to describe the set *Bad*, i.e. the set of points in which the rank of all brackets falls. This is the set where our constructions do not work.

Proposition 6.8.1. *Let M be a regular equilibrium. Then $M \in \text{Bad}$ if and only if*

$$\dim \text{Ker } M > 2.$$

In other words, there are more than two fixed axes in the even-dimensional case or more than one in the odd-dimensional case.

The proof can be found in Section 6.13.

The construction of Section 1.5 allows us to obtain an involutive system of integrals in the neighbourhood of any point $M \notin \text{Bad}$. But in our case there are globally defined integrals (because Casimir functions of all brackets of the pencil are globally defined). It is easy to check that the global system of integrals locally coincides with the local one (which is not always the case, see Example 2.4.1). Therefore, it is possible to apply the theorems of the first part of the thesis to these global integrals.

However, we still cannot say anything about the points which belong to the *Bad* set (though our global integrals are defined on this set as well).

6.9 Complete integrability

Liouville integrability of Euler-Arnold equations was proved in [30]. This can also be easily done using Theorem 5. We have

$$S = \left(\bigcup_{\lambda \in \overline{\mathbb{C}} \setminus \sigma(J^2)} S_\lambda \right) \cup \left(\bigcup_{\lambda \in \sigma(J^2)} S_\lambda \right),$$

where

$$S_\lambda = \{x : \text{rank } P_\lambda(x) < \text{rank } \Pi\}$$

and $\sigma(J^2)$ is the spectrum of J^2 .

All sets S_λ for $\lambda \notin \sigma(J^2)$ have codimension three, because corresponding brackets are Lie-Poisson brackets of semisimple algebras. Consequently, their union has measure zero. Therefore, to prove that S has measure zero, it suffices to check that algebras which we get for $\lambda \in \sigma(J^2)$ have the same index as semisimple algebras in the pencil. But it is easy to see that these algebras (after complexification) are isomorphic to $\mathfrak{e}(n-1)$, where n is the dimension of our body. But index of $\mathfrak{e}(n-1)$ equals index of $\mathfrak{so}(n)$, q.e.d.

We may also apply another argument, which is in some sense better, because it allows us to prove complete integrability on a *given* symplectic leaf (while the previous argument only proves it on almost all leaves):

If a symplectic leaf contains a non-degenerate singular point, then there is complete integrability on this leaf. This is due to the fact that there always exists a regular point in the neighbourhood of a non-degenerate singular point. But our system is analytic, therefore regular points are everywhere dense on the symplectic leaf.

This may sound strange, because non-degeneracy is usually defined for systems which are already known to be completely integrable. But actually the definition of non-degeneracy works for any involutive system of integrals.

And if the condition of non-degeneracy is satisfied, then the system of integrals is automatically complete.

We will give a simple criteria (see Section 6.11) which makes it possible to check non-degeneracy of a zero rank singular point. Therefore, we have a simple sufficient condition for completeness on a given symplectic leaf.

It is a kind of a combinatorial problem to prove that there is a non-degenerate point on each regular symplectic leaf (and, therefore, there is complete integrability on each orbit). This problem is not discussed in the thesis.

6.10 Rank zero singular points

Theorem 16 (Bolsinov, Oshemkov, see [8]). *$M \notin \text{Bad}$ is a zero-rank singular point if and only if there exists an orthonormal basis such that J is diagonal and M is block-diagonal with two-by-two blocks on the diagonal (i.e. M is a regular equilibrium point).*

Proof. M is a zero-rank singular point if and only if Hamiltonian vector fields generated by all the integrals vanish in this point, i.e. $P_\alpha d\mathcal{F} = 0$. But we know that $d\mathcal{F} = L$, where L is the sum of kernels of regular brackets. Therefore,

$$L \subset \text{Ker } P_\alpha.$$

But

$$\dim L \cap \text{Ker } P_\alpha = \text{corank } \Pi,$$

therefore

$$\dim L = \text{corank } \Pi$$

and the kernels of all regular brackets at point M coincide. On the other

hand, if the kernels coincide, then $P_\alpha d\mathcal{F} = 0$ and M is a zero-rank singular point.

If M is block diagonal with two-by-two blocks on the diagonal and J is diagonal, then the set of block-diagonal skew-symmetric matrices with two-by-two blocks on the diagonal lies in kernel of all brackets. By dimension argument this set coincides with kernel for almost all brackets, which means that our point is a zero-rank singular point.

Vice versa, let M be a point such that the kernels of all regular brackets coincide at M . First let us consider the case when the standard $\mathfrak{so}(n)$ bracket is regular at M . This means that M is a matrix with pairwise distinct eigenvalues.

Now find an orthonormal basis such that M is block-diagonal with two-by-two blocks on the diagonal. The kernel of $\mathfrak{so}(n)$ bracket coincides with the centraliser of M . Consequently, it is just the set of block-diagonal skew-symmetric matrices with two-by-two blocks on the diagonal. Since the kernel is common, we have

$$\langle M, XJ^2Y - YJ^2X \rangle = 0$$

for all $X \in K$ and all Y .

Suppose that $B = J^2$ is not diagonal, i.e. $b_{ij} \neq 0$ for some $i \neq j$. Take $Y = E_{ij} - E_{ji}$. Then

$$(J^2Y)_{ii} = -b_{ij},$$

$$(YJ^2)_{ii} = b_{ij},$$

$$(J^2Y)_{jj} = b_{ij},$$

$$(YJ^2)_{jj} = -b_{ij},$$

and all other diagonal elements vanish.

Take $X = M$. Then

$$\langle M, XJ^2Y - YJ^2X \rangle = -\text{Tr } M^2(J^2Y - YJ^2) = 2b_{ij}((M^2)_{jj} - (M^2)_{ii}).$$

Since M is regular, $(M^2)_{ii} - (M^2)_{jj}$ can only be zero in the case when $i = 2k, j = 2k + 1$ or vice versa. Consequently, J has block-diagonal form with two-by-two blocks on the diagonal. But for such J we can find an orthogonal transformation which preserves Ω and brings J to diagonal form.

Now let us consider the case when the standard bracket is singular at point M . Since $M \notin \text{Bad}$, there is a bracket $\{, \}_\lambda$ in our pencil which is still regular at M . Moreover, since almost all brackets of the pencil are regular at M , we can choose a regular bracket $\{, \}_\lambda$ such that $J^2 - \lambda E$ is positive definite. Denote

$$A = \sqrt{J^2 - \lambda E}$$

and consider transformation $\phi: \mathfrak{so}(n) \rightarrow \mathfrak{so}(n)$ given by

$$\phi(X) = AXA.$$

It is easy to see that

$$\begin{aligned} \phi([X, Y]) &= \phi(X)A^{-2}\phi(Y) - \phi(Y)A^{-2}\phi(X), \\ \phi([X, Y]_\lambda) &= [\phi(X), \phi(Y)]. \end{aligned}$$

Consequently, our pencil is mapped to the pencil

$$\widetilde{[X, Y]_\lambda} = X(A^{-2} - \lambda E)Y - Y(A^{-2} - \lambda E)X.$$

The point $\phi^*(M) = A^{-1}MA^{-1}$ is going to be the point where all brackets of the new pencil have coinciding kernels. This point is regular with respect to the standard bracket, consequently there is an orthogonal transformation which brings A^{-2} to diagonal form and $A^{-1}MA^{-1}$ to block-diagonal form. But this implies that J and M will have necessary form as well. \square

6.11 Non-degeneracy and type theorems

Theorem 17. *Zero-rank singular point $M \notin \text{Bad}$ is non-degenerate if and only if the parabolic diagram of M is generic.*

Remark 6.11.1. A sufficient condition for non-degeneracy is given in [8]. In our terms it means the following:

- The parabolic diagram is generic.
- For each λ there is no more than one intersection point on the parabolic diagram with x coordinate equal to λ .

Theorem 18. *The type of a non-degenerate zero-rank singular point $M \notin \text{Bad}$ is (k_e, k_h, k_f) , where*

- k_e is the number of real intersections on the parabolic diagram in the upper half-plane plus the number of intersections at infinity,
- k_h is the number of real intersections in the lower half-plane,
- k_f is half the number of complex intersections.

Sections 6.12-6.16 are dedicated to the proof of these theorems.

Example 6.11.1 (Three-dimensional body). Rotations around the longest and the shortest axes are elliptic singular points (see parabolic diagrams on figures 6.2, 6.4). Rotation around the middle axis is a hyperbolic singularity (see parabolic diagram on figure 6.3).

Example 6.11.2 (Four-dimensional body). The first case from example 6.5.2 corresponds to a center-center singular point (see figure 6.5).

The second case corresponds to a center-saddle singular point (see figure 6.6).

In the third case everything depends on the ratio of angular velocities. As we change the angular velocity of rotation in the “inner” plane, the following bifurcations occurs:

Center-center (figure 6.7) \rightarrow degenerate (figure 6.10) \rightarrow focus-focus (figure 6.8) \rightarrow degenerate (figure 6.11) \rightarrow saddle-saddle (figure 6.9).

6.12 Non-degeneracy: scheme of the proof

According to the general scheme stated in section 2.4 to prove non-degeneracy and find type of singular point M we should do the following:

- Find those λ , for which the rank of $P_\lambda(M)$ drops down, i.e. describe the set $\Lambda(M)$. This is done in section 6.13.
- Check that the pencil is diagonalizable at M . This is done in section 6.14.
- Linearize the pencil, check that linearisations are non-degenerate and find their type. This is done in section 6.15.
- Collect all this together. This is done in section 6.16.

6.13 Description of $\Lambda(M)$

Let M be a zero-rank singular point. Let us find a basis such that J is diagonal and M is block-diagonal. Let us introduce the following subspaces:

- $K \subset \mathfrak{so}(n)$ is generated by $E_{2i-1,2i} - E_{2i,2i-1}$ where $i = 1, \dots, m$ and all $E_{ij} - E_{ji}$ for $2m < i < j \leq n$.

Proposition 6.13.2. *The form P_λ restricted on V_{ij} has the form*

$$P_\lambda(X, Y) = 2\text{Tr}(M_i X A_j Y^t + M_j X^t A_i Y).$$

The form P_λ restricted on W_{ij} has the form

$$P_\lambda(v, w) = -2a_j M_i(v, w).$$

Proof. This is a straightforward computation. □

Let us now calculate P_λ on V_{ij} in coordinates. Let

$$M_s = \begin{pmatrix} 0 & m_s \\ -m_s & 0 \end{pmatrix}, A_s = \begin{pmatrix} a_{2s-1} & 0 \\ 0 & a_{2s} \end{pmatrix}.$$

Let also

$$X = \begin{pmatrix} a & b \\ c & d \end{pmatrix}, Y = \begin{pmatrix} e & f \\ g & h \end{pmatrix}.$$

Explicit calculation shows that

$$\begin{aligned} P_\lambda(X, Y) &= 2(m_i a_{2j-1} c + m_j a_{2i-1} b) e + 2(m_j a_{2i} d - m_i a_{2j-1} a) g + \\ &+ 2(m_i a_{2j} d - m_j a_{2i-1} a) f - 2(m_i a_{2j} b + m_j a_{2i} c) h. \end{aligned}$$

Consequently $X \in \text{Ker } P_\lambda$ if and only if

$$\begin{cases} m_i a_{2j-1} c + m_j a_{2i-1} b = 0, \\ m_j a_{2i} d - m_i a_{2j-1} a = 0, \\ m_i a_{2j} d - m_j a_{2i-1} a = 0, \\ m_i a_{2j} b + m_j a_{2i} c = 0. \end{cases}$$

This system can be splitted onto two two-by-two systems and the determinant of both of them equals

$$\det = m_j^2 a_{2i-1} a_{2i} - m_i^2 a_{2j-1} a_{2j}.$$

Consequently, we have proved the following

Proposition 6.13.3. P_λ is degenerate on V_{ij} if and only if

$$m_j^2 a_{2i-1} a_{2i} - m_i^2 a_{2j-1} a_{2j} = 0, \quad (6.5)$$

where $a_s = \lambda_s^2 - \lambda$ if $\lambda \neq \infty$ and $a_s = 1$ if $\lambda = \infty$.

The kernel in this case is given by

$$\begin{cases} a = \alpha m_j a_{2i}, \\ b = \beta m_i a_{2j-1}, \\ c = -\beta m_j a_{2i-1}, \\ d = \alpha m_i a_{2j-1}, \end{cases}$$

where α and β are arbitrary numbers.

Now we shall study P_λ on W_{ij} . The following is straightforward

Proposition 6.13.4. P_λ is degenerate on W_{ij} if and only if $a_j = 0$ where $a_j = \lambda_j^2 - \lambda$ if $\lambda \neq \infty$ and $a_j = 1$ otherwise.

Proposition 6.13.5. The intersection of kernels of all brackets of the pencil is exactly K . For almost all brackets the kernel is exactly K .

Proof. Indeed, only finite number of brackets are degenerate on each V_{ij} and W_{ij} . □

Now we are able to describe the *Bad* set.

Proof of Proposition 6.8.1. Indeed, for almost all brackets the kernel is exactly K , which means that all brackets are degenerate if and only if

$$\dim K > \left\lfloor \frac{n}{2} \right\rfloor.$$

This is equivalent to the condition $\dim \text{Ker } M > 2$, q.e.d. □

Now we can prove the following

Proposition 6.13.6. *Let $M \notin \text{Bad}$. Then $\Lambda(M)$ is the set of x coordinates of the intersections on the parabolic diagram of M .*

Proof. P_λ is degenerate on V_{ij} if and only if $m_j^2 a_{2i-1} a_{2i} - m_i^2 a_{2j-1} a_{2j} = 0$.

This can be rewritten as

$$\chi_i(\lambda) = \chi_j(\lambda).$$

But this means that λ is the x coordinate of the intersection point of two parabolas.

Further, P_λ is degenerate on W_{ij} if and only if $a_j = 0$ or, which is the same, $\lambda_j^2 - \lambda = 0$. But this means that λ is the x coordinate of the intersection point of the vertical line with any parabola. \square

6.14 When is the pencil diagonalizable?

As a next step, we should check that the pencil is diagonalizable at point M .

Proposition 6.14.1. *The pencil is diagonalizable at point $M \notin \text{Bad}$ if and only if any two parabolas on the parabolic diagram of M intersect at two different points.*

Proof. Proposition 3.2.2 implies that a pencil is diagonalizable if and only if

$$L^\perp/L = \bigoplus_{\lambda \in \Lambda(M)} \text{Ker} (P_\lambda |_{L^\perp/L}).$$

In our case L is the common kernel K and L^\perp/L can be naturally identified with

$$\bigoplus_{1 \leq i < j \leq m} V_{ij} \oplus \bigoplus_{\substack{1 \leq i \leq m, \\ 2m < j \leq n}} W_{ij},$$

therefore the following relation must be satisfied:

$$\bigoplus_{1 \leq i < j \leq m} V_{ij} \oplus \bigoplus_{\substack{1 \leq i \leq m, \\ 2m < j \leq n}} W_{ij} = \bigoplus_{\lambda \in \Lambda(M)} \text{Ker} (P_\lambda |_{L^\perp/L}).$$

This is satisfied if and only if

$$V_{ij} = \bigoplus_{\lambda \in \Lambda(M)} V_{ij} \cap \text{Ker} (P_\lambda |_{L^\perp/L}) \quad (6.6)$$

for $1 \leq i < j \leq m$ and

$$W_{ij} = \bigoplus_{\lambda \in \Lambda(M)} W_{ij} \cap \text{Ker} (P_\lambda |_{L^\perp/L}) \quad (6.7)$$

for $1 \leq i \leq m, 2m < j \leq n$.

For each W_{ij} there is a unique λ such that

$$W_{ij} = W_{ij} \cap \text{Ker} (P_\lambda |_{L^\perp/L}).$$

This follows from Proposition 6.13.4. Therefore, relation (6.7) is always satisfied.

Relation (6.6) is satisfied if and only if the equation (6.5) has two distinct roots, i.e. if two corresponding two parabolas are not tangent to each other, q.e.d. \square

6.15 Linearization

The last step is to linearise the pencil and to check whether the linearizations are non-degenerate. We have

$$\mathfrak{so}(n) = K \oplus \bigoplus_{1 \leq i < j \leq m} V_{ij} \oplus \bigoplus_{\substack{1 \leq i \leq m, \\ 2m < j \leq n}} W_{ij}.$$

The kernel of each $P_\lambda(M)$ can be decomposed in the following way

$$\text{Ker } P_\lambda = K \oplus \bigoplus_{1 \leq i < j \leq m} \widetilde{V}_{ij} \oplus \bigoplus_{\substack{1 \leq i \leq m, \\ 2m < j \leq n}} \widetilde{W}_{ij},$$

where $\widetilde{V}_{ij} \subset V_{ij}, \widetilde{W}_{ij} \subset W_{ij}$.

Proposition 6.15.1. *Spaces $\widetilde{V}_{ij}, \widetilde{W}_{ij}$ are invariant with respect to adjoint operators ad_X in \mathfrak{g}_λ , where $X \in K$.*

Proof. Linearization \mathfrak{g}_λ is simply a stabilizer of M with respect to the bracket $[\cdot, \cdot]_\lambda$. Consequently, the commutator in \mathfrak{g}_λ has the form

$$[X, Y]_\lambda = XAY - YAX,$$

where $A = J^2 - \lambda E$ for finite λ and $A = E$ for $\lambda = \infty$.

Let $X \in K, Y \in V_{ij}$. Then it is easy to see that $[X, Y] \in V_{ij}$, which means that $\text{ad}_X(V_{ij}) \subset V_{ij}$. But $\widetilde{V}_{ij} = V_{ij} \cap \text{Ker } P_\lambda$, therefore \widetilde{V}_{ij} is invariant. The proof for \widetilde{W}_{ij} is the same. \square

Now represent an element $X \in K$ as

$$X = \begin{pmatrix} 0 & x_1 & & & & \\ -x_1 & 0 & & & & \\ & & 0 & x_2 & & \\ & & -x_2 & 0 & & \\ & & & & \ddots & \\ & & & & & \ddots \end{pmatrix}.$$

Proposition 6.15.2. *Consider the case when \widetilde{V}_{ij} is non-empty. Then the eigenvalues of ad_X restricted on \widetilde{V}_{ij} are $\pm \nu_{ij}(X)$, where*

$$\nu_{ij}(X) = \sqrt{-\chi_i(\lambda)}(m_j x_j - m_i x_i).$$

Proof. Let X_1, \dots be the diagonal two-by-two blocks of X , and Y is a two-by-two matrix representing an element of V_{ij} . Let also A_1, \dots, A_m be the diagonal two-by-two blocks of A . Then

$$[X, Y]_\lambda = X_i A_i Y - Y A_j X_j.$$

Straightforward computation shows that ad_X sends

$$Y = \begin{pmatrix} a & b \\ c & d \end{pmatrix}$$

to the matrix

$$\text{ad}_X Y = \begin{pmatrix} x_i a_{2i} c + x_j a_{2j} b & x_i a_{2i} d - x_j a_{2j-1} a \\ -x_i a_{2i-1} a + x_j a_{2j} d & -x_i a_{2i-1} b - x_j a_{2j-1} c \end{pmatrix} \quad (6.8)$$

\tilde{V}_{ij} consists of matrices Y having form

$$Y(\alpha, \beta) = \begin{pmatrix} \alpha m_j a_{2i} & \beta m_i a_{2j-1} \\ -\beta m_j a_{2i-1} & \alpha m_i a_{2j-1} \end{pmatrix}$$

Substituting this into the formula (6.8), we get

$$\begin{pmatrix} -\beta(m_j a_{2i-1} a_{2i} x_i - m_i a_{2j-1} a_{2j} x_j) & \alpha(m_i a_{2j-1} a_{2i} x_i - m_j a_{2i} a_{2j-1} x_j) \\ * & * \end{pmatrix}$$

Therefore, in coordinates (α, β) the map ad_X restricted to \tilde{V}_{ij} has the form

$$\begin{pmatrix} 0 & a_{2i}(x_i - \frac{m_j}{m_i} x_j) \\ -a_{2i-1}(x_i - \frac{m_j}{m_i} x_j) & 0 \end{pmatrix} \quad (6.9)$$

The determinant of matrix (6.9) equals

$$\det = -a_{2i} a_{2i-1} (x_i - \frac{m_j}{m_i} x_j)^2,$$

which gives us the desired formula for the eigenvalues. \square

Proposition 6.15.3. *Consider the case when \widetilde{W}_{ij} is non-empty. Then the eigenvalues of ad_X restricted on \widetilde{W}_{ij} are $\pm\mu_i(X)$, where*

$$\mu_i(X) = \sqrt{-\chi_i(\lambda)}m_ix_i.$$

Proof. Represent an element of W_i by a vector $v \in \mathbb{R}^2$. Then

$$[X, v]_\lambda = X_i A_i v,$$

which means that ad_X restricted to W_i is given by the matrix

$$X_i A_i = \begin{pmatrix} 0 & x_i a_{2i} \\ -x_i a_{2i-1} & 0 \end{pmatrix},$$

and the eigenvalues have the desired form. □

Consider the following set R of linear functions on X :

$$R = \{\nu_{ij}(X), \text{ where } i, j \text{ are such that } \widetilde{V}_{ij} \neq 0\} \cup \\ \cup \{\mu_i(X), \text{ where } i \text{ is such that } \widetilde{W}_{ij} \neq 0 \text{ for some } j\}$$

Now we see that the following is true

Proposition 6.15.4. *K is a diagonalizable subalgebra in \mathfrak{g}_λ . The set of roots of \mathfrak{g}_λ with respect to K is the set $\{\pm\xi, \xi \in R\}$.*

Proposition 6.15.5. *λ -linearization of the pencil is non-degenerate at M if and only if there are no three objects (which may be parabolas or vertical lines) on the parabolic diagram which intersect at a point with x coordinate equal to λ .*

Proof. To prove our proposition it suffices to show that the linear functions belonging to R are independent if and only if there are on three objects on

the parabolic diagram which intersect at a point with x coordinate equal to λ .

First note that up to multiplication on non-zero constant the elements of R are

$$\begin{aligned}\tilde{\nu}_{ij}(X) &= m_i x_i - m_j x_j, \\ \tilde{\mu}_i(X) &= m_i x_i.\end{aligned}$$

If there are three parabolas intersecting at one point (with x coordinate equal to λ), then the spaces $\tilde{V}_{ij}, \tilde{V}_{jk}, \tilde{V}_{ik}$ are non-empty for some different i, j, k . But this implies that R contains $\tilde{\nu}_{ij}, \tilde{\nu}_{jk}, \tilde{\nu}_{ik}$ and since

$$\tilde{\nu}_{ij} + \tilde{\nu}_{jk} = \tilde{\nu}_{ik},$$

the elements of R are not independent and the linearization is degenerate (see Proposition 5.1.1).

Now suppose that there is an intersection of two parabolas and one vertical line. Then R contains $\tilde{\nu}_{ij}, \tilde{\mu}_i, \tilde{\mu}_j$ and since

$$\tilde{\nu}_{ij} = \tilde{\mu}_i - \tilde{\mu}_j,$$

the elements of R are not independent and the linearization is again degenerate.

Vice versa, suppose we do not have any triple intersections. Consider some intersection point. One of the intersecting objects is necessary a parabola. Therefore R contains either some $\tilde{\nu}_{ij} = m_i x_i - m_j x_j$ or $\tilde{\mu}_i = m_i x_i$. The coefficient in front of x_i is non-zero in both cases. But there are no other elements of R , containing the term $m_i x_i$. Indeed, a parabola can't intersect any other object at a point with the same x coordinate. Therefore, the element of R which is given by each pairwise intersection is independent with

other elements of R , which means that R is independent and the linearization is indeed non-degenerate. \square

Proposition 6.15.6. *Let the λ -linearization of the pencil be non-degenerate at M , where λ is real. Then the type of $\text{Sing}(d_\lambda \Pi(M))$ is $(k_e, k_h, 0)$, where*

- k_e is the number of intersections on the parabolic diagram such that their x coordinate is λ and their y coordinate is positive;
- k_h is the number of intersections on the parabolic diagram such that their x coordinate is λ and their y coordinate is negative.

Proof. Indeed, each intersection of parabolas correspond to the pair of roots $\pm \nu_{ij}(X)$, where

$$\nu_{ij}(X) = \sqrt{-\chi_i(\lambda)}(m_j x_j - m_i x_i).$$

The y coordinate of the intersection point is

$$y = \chi_i(\lambda).$$

ν_{ij} is real if and only if this number is negative.

Intersection of a parabola with a vertical line corresponds to a pair $\pm \mu_i(X)$, where

$$\mu_i(X) = \sqrt{-\chi_i(\lambda)} m_i x_i.$$

Again μ_i is real if and only if the y coordinate of the intersection given by

$$y = \chi_i(\lambda)$$

is negative.

We conclude that the number of pairs of real roots equals number of intersections in the lower half-plane, while the number of pairs of imaginary roots equals number of intersections in the upper half-plane. Taking into account Proposition 5.1.1, this proves our proposition. \square

Remark 6.15.1. Note that we didn't calculate algebras \mathfrak{g}_λ explicitly. Instead of this we calculated their roots and used Proposition 5.1.1. However, it is easy to show that

- Intersection of two parabolas above the x axis corresponds to $\mathfrak{sl}(2)$ if the intersection point belongs to the left branch of one parabola and to the right branch of another parabola.
- Intersection of two parabolas above the x axis corresponds to $\mathfrak{so}(3)$ if the intersection point belongs to either left or right branch of both parabolas. Intersection at infinity also corresponds to $\mathfrak{so}(3)$.
- Intersection of two parabolas below the x axis corresponds to $\mathfrak{sl}(2)$.
- Intersection of two parabolas at a complex point corresponds to $\mathfrak{so}(3, \mathbb{C})$.
- Intersection of a parabola with a vertical line above the x axis corresponds to $\mathfrak{e}(2)$.
- Intersection of a parabola with a vertical line below the x axis corresponds to $\mathfrak{e}(1, 1)$.

6.16 Proof of non-degeneracy and type theorems

Proof of Theorem 17. M is non-degenerate if and only if the pencil is diagonalizable at M and all linearizations are non-degenerate (Theorem 8). Pencil is diagonalizable if and only if any two parabolas intersect exactly at two points (Proposition 6.14.1). All linearizations are non-degenerate if and

only if there are no multiple intersections (Proposition 6.15.5). But these two conditions together give exactly the condition for a parabolic diagram to be generic. \square

Proof of Theorem 18. By Theorem 9, the type of a singular point M is k_e, k_h, k_f , where

$$\begin{aligned} k_e &= \sum_{\lambda \in \Lambda(M) \cap \bar{\mathbb{R}}} k_e(\lambda), \\ k_h &= \sum_{\lambda \in \Lambda(M) \cap \bar{\mathbb{R}}} k_h(\lambda), \\ k_f &= \sum_{\lambda \in \Lambda(M) \cap \bar{\mathbb{R}}} k_f(\lambda) + \frac{1}{2} \sum_{\substack{\lambda \in \Lambda(x), \\ \text{Im } \lambda > 0}} (\dim_{\mathbb{C}} \text{Ker } P_\lambda - \text{corank } \Pi), \end{aligned}$$

and $(k_e(\lambda), k_h(\lambda), k_f(\lambda))$ is the type of $\text{Sing}(d_\lambda \Pi(M))$.

Let λ be real (or infinite). Then $k_e(\lambda)$ is the number of intersections with $x = \lambda, y > 0$, $k_h(\lambda)$ is the number of intersections with $x = \lambda, y < 0$, and $k_f(\lambda) = 0$ (Proposition 6.15.6). Therefore,

$$\begin{aligned} \sum_{\lambda \in \Lambda(M) \cap \bar{\mathbb{R}}} k_e(\lambda) &= \text{the number of intersections in the upper half-plane,} \\ \sum_{\lambda \in \Lambda(M) \cap \bar{\mathbb{R}}} k_h(\lambda) &= \text{the number of intersections in the lower half-plane,} \\ \sum_{\lambda \in \Lambda(M) \cap \bar{\mathbb{R}}} k_f(\lambda) &= 0. \end{aligned}$$

If λ is complex, then

$$\frac{1}{2} (\dim_{\mathbb{C}} \text{Ker } P_\lambda - \text{corank } \Pi)$$

is the number of intersections with $x = \lambda$. Since we count λ with $\text{Im } \lambda \geq 0$, this sum is one half of the total number of complex intersections. The theorem is proved. \square

6.17 Non-resonancy

Theorem 19. *The system of Euler-Arnold equations is non-resonant, i.e. the trajectories of this system are dense on almost all Liouville tori.*

First we will prove several preliminary statements.

Proposition 6.17.1. *Let M be a regular equilibrium such that the parabolic diagram of M is generic and all the eigenvalues of M are distinct. Then the eigenvalues of the linearization of the Euler-Arnold vector field at M are $\pm\sigma_{ij}^{1,2}$, where*

$$\sigma_{ij}^{1,2} = \frac{1}{\sqrt{-\chi_i(x_{ij}^{1,2})}} \left(\frac{x_{ij}^{1,2} + \lambda_{2i-1}\lambda_{2i}}{\lambda_{2i-1} + \lambda_{2i}} - \frac{x_{ij}^{1,2} + \lambda_{2j-1}\lambda_{2j}}{\lambda_{2j-1} + \lambda_{2j}} \right),$$

where $1 < i < j \leq [n/2]$ and $x_{ij}^{1,2}$ are two roots of the equation $\chi_i(x) = \chi_j(x)$.

If the dimension is odd, there are also eigenvalues $\pm\tau_i$, where

$$\tau_i = \frac{1}{\sqrt{-\chi_i(\lambda_n^2)}} \left(\frac{\lambda_n^2 + \lambda_{2i-1}\lambda_{2i}}{\lambda_{2i-1} + \lambda_{2i}} - \lambda_n \right),$$

where $1 < i \leq [n/2]$.

Proof. Instead of the linearization of $\text{sgrad } H$, we can consider the operator $D = D_H P_\infty$.

Since $P_\lambda dH_\lambda = P_\infty dH$, we have $D = D_H P_\infty = D_{H_\lambda} P_\lambda$.

Since the parabolic diagram of M is generic, the pencil is diagonalizable at M , and there is a decomposition

$$T_M^* \mathfrak{so}(n)^* / K = \bigoplus_{\lambda \in \Lambda(M)} \text{Ker } P_\lambda(M) / K, \quad (6.10)$$

where K is the common kernel of regular brackets of the pencil at point M .

Since $\text{Ker } P_\lambda$ is invariant with respect to $D_{H_\lambda} P_\lambda$, the decomposition (6.10) is invariant with respect to the operator D . Now note that

$$D|_{\text{Ker } P_\lambda} = \text{ad}_{dH_\lambda}.$$

Now, applying Propositions 6.15.2, 6.15.3 and taking into account formula (6.4), we get the formula for the eigenvalues. \square

Proposition 6.17.2. *Let $\lambda_{2i-1}\lambda_{2i} \neq \lambda_{2j-1}\lambda_{2j}$ for all i, j . Then $\sigma_{ij}^{1,2}$ and τ_i are linearly independent as functions of M .*

Proof. Suppose that

$$\sum_{1 < i < j \leq [n/2]} (a_{ij}^1 \sigma_{ij}^1 + a_{ij}^2 \sigma_{ij}^2) + \sum_{1 < i \leq [n/2]} b_i \tau_i = 0.$$

Fix k and choose those members which do not depend on m_k . Their sum does not depend on m_k , therefore the sum of all other members

$$S_k = \sum_{1 < i < k} (a_{ik}^1 \sigma_{ik}^1 + a_{ik}^2 \sigma_{ik}^2) + \sum_{k < j \leq [n/2]} (a_{kj}^1 \sigma_{kj}^1 + a_{kj}^2 \sigma_{kj}^2) + b_k \tau_k. \quad (6.11)$$

does not depend on m_k as well. For simplicity denote

$$\sigma_{jk} = -\sigma_{kj}, a_{jk} = -a_{kj}$$

and rewrite (6.11) as

$$S_k = \sum_{i \neq k} (a_{ik}^1 \sigma_{ik}^1 + a_{ik}^2 \sigma_{ik}^2) + b_k \tau_k. \quad (6.12)$$

Let m_k tend to zero. It is easy to see that

$$\begin{aligned} \lim_{m_k \rightarrow 0} \sigma_{ik}^{1,2} &= 0, \\ \lim_{m_k \rightarrow 0} \tau_k &= 0. \end{aligned}$$

Consequently,

$$\lim_{m_k \rightarrow 0} S_k = 0.$$

But S_k does not depend on m_k which means that $S_k = 0$.

Now fix $l \neq k$. Again, there are two summands in (6.12), which depend on m_l . Their sum

$$S_{lk} = a_{lk}^1 \sigma_{lk}^1 + a_{lk}^2 \sigma_{lk}^2$$

must not depend on m_l . But this sum tends to 0 as $m_l \rightarrow 0$, therefore $S_{lk} = 0$. But

$$\begin{aligned} \lim_{m_k \rightarrow \infty} \sigma_{lk}^1 &= Am_l, \\ \lim_{m_k \rightarrow \infty} \sigma_{lk}^2 &= Bm_l, \end{aligned}$$

where

$$\begin{aligned} A &= \frac{1}{\lambda_{2l-1} + \lambda_{2l}} \sqrt{-\frac{1}{(\lambda_{2k-1} + \lambda_{2l-1})(\lambda_{2k-1} + \lambda_{2l})}}, \\ B &= \frac{1}{\lambda_{2l-1} + \lambda_{2l}} \sqrt{-\frac{(\lambda_{2k} - \lambda_{2l-1})(\lambda_{2k} - \lambda_{2l})}{(\lambda_{2k} + \lambda_{2l-1})(\lambda_{2k} + \lambda_{2l})}}. \end{aligned}$$

Consequently,

$$a_{lk}^1 A + a_{lk}^2 B = 0.$$

On the other hand,

$$\begin{aligned} \lim_{m_l \rightarrow \infty} \sigma_{lk}^1 &= Cm_k, \\ \lim_{m_l \rightarrow \infty} \sigma_{lk}^2 &= Dm_k, \end{aligned}$$

$$\begin{aligned} C &= -\frac{1}{\lambda_{2k-1} + \lambda_{2k}} \sqrt{-\frac{(\lambda_{2l-1} - \lambda_{2k-1})(\lambda_{2l-1} - \lambda_{2k})}{(\lambda_{2l-1} + \lambda_{2k-1})(\lambda_{2l-1} + \lambda_{2k})}}, \\ D &= -\frac{1}{\lambda_{2k-1} + \lambda_{2k}} \sqrt{-\frac{(\lambda_{2l} - \lambda_{2k-1})(\lambda_{2l} - \lambda_{2k})}{(\lambda_{2l} + \lambda_{2k-1})(\lambda_{2l} + \lambda_{2k})}}. \end{aligned}$$

Consequently,

$$a_{lk}^1 C + a_{lk}^2 D = 0.$$

It is easy to see that $AD - BC = 0$ if and only if $\lambda_{2l-1}\lambda_{2l} = \lambda_{2k-1}\lambda_{2k}$. But we assumed that this equality is not satisfied. Therefore

$$a_{lk}^1 = a_{lk}^2 = 0.$$

Since k and l were arbitrary, all coefficients $a_{ij}^{1,2}$ vanish. But this implies that b_i vanish as well and our functions are linearly independent, q.e.d. \square

Remark 6.17.1. It is easy to see that if $\lambda_{2i-1}\lambda_{2i} = \lambda_{2j-1}\lambda_{2j}$ for some i, j , then $\sigma_{ij}^1 = \sigma_{ij}^2$, which means that the eigenvalues are not linearly independent.

Lemma 6.17.1. *Let f_1, \dots, f_n be continuous functions on a manifold N . Suppose that these functions are linearly independent on any open subset $V \subset N$. Then their values are independent over \mathbb{Z} almost everywhere on N .*

Proof. Assume that this is not the case. Then there is a closed ball $V_0 \subset N$ such that the numbers $f_1(x), \dots, f_n(x)$ are dependent over \mathbb{Z} for any $x \in V_0$.

Denote $f(x) = (f_1(x), \dots, f_n(x)) \in \mathbb{R}^n$. Let

$$\Gamma(x) = \{v \in \mathbb{Z}^n \text{ such that } \langle v, f(x) \rangle = 0\}.$$

By our assumption $\Gamma(x)$ is non-empty for all $x \in V_0$. Let

$$l(x) = \min_{v \in \Gamma(x)} \|v\|$$

Let also

$$K_v = \{x : \langle v, f(x) \rangle = 0\}.$$

We claim that we can find a closed ball $V_1 \subset V_0$ such that

$$\min_{x \in V_1} l(x) > 1.$$

Indeed,

$$\{x : l(x) \leq 1\} = \bigcup_{v: \|v\| \leq 1} K_v.$$

The sets K_v are closed and nowhere dense by linear independency assumption and there is only finite number of them in the union. Therefore, this union is also closed and nowhere dense and we can find V_1 with the desired property.

Analogously, we can find a sequence

$$V_0 \supset V_1 \supset V_2 \supset \dots$$

of closed balls such that

$$\min_{x \in V_1} l(x) > i.$$

Since the balls V_i are closed, there is a point x which belongs of them. The value of $l(x)$ for this point must be bigger than any natural number. Contradiction.

□

Proof of Theorem 19. Let us consider an equilibrium M such that $\lambda_1 < \lambda_2 < \dots$ and the parabolic diagram is generic. In the neighbourhood of M eigenvalues of $\text{sgrad } H$ are linearly independent. Then, by the previous lemma, they are independent over \mathbb{Z} almost everywhere. Take a point M_1 such that they are independent. We claim that our system is non-resonant in the neighbourhood of M_1 . Indeed, M_1 is an elliptic point and the Liouville foliation on any regular symplectic leaf passing through M_1 is locally given by the functions

$$s_1 = p_1^2 + q_1^2, \dots, s_m = p_m^2 + q_m^2$$

in some symplectic coordinates p, q (see Theorem 3).

The functions s_i are action variables and the rotation numbers are given by

$$c_i(s_1, \dots, s_m) = \frac{\partial H}{\partial s_i}.$$

It is easy to see that $c_i(0)$ are exactly eigenfrequencies of $\text{sgrad } H$. They are independent over \mathbb{Z} . But this implies that c_i are independent on almost

all tori in the neighbourhood of M_1 and our system is non-resonant. By analyticity, it is non-resonant everywhere. \square

6.18 Proof of stability theorems

Proof of Theorem 12. Take a regular symplectic leaf O passing through M . The conditions of the theorem imply that the point M has pure elliptic type on O . Therefore, there exists an integral f such that

$$\begin{aligned} f(M) &= 0, \\ d(f|_O)(M) &= 0 \end{aligned}$$

and the Hessian of $f|_O$ is positive definite at M .

Since O is regular there exists a coordinate system x_1, \dots, x_N in the neighborhood of M such that

$$O = \{x_i = 0, i = 1, \dots, k\}.$$

Now it is easy to see that

$$f^2 + \sum_{i=1}^k x_i^2$$

is a Lyapunov function. \square

To prove the instability theorem, we will need the following

Lemma 6.18.1 (About unstable cone). *Let a vector field v on a manifold M^n vanish at point x_0 . Suppose that the linearization of v at x_0 has an eigenvalue with a positive real part. Then there is an open subset $K \subset M^n$ such that*

1. *There exists $\delta > 0$ such that all trajectories starting at K leave $U_\delta(x_0)$.*

2. *Intersection of K with any open neighbourhood of x_0 has non-empty interior.*

Proof of lemma. First suppose that the linearization of v has a real eigenvalue $\lambda > 0$. Then we can find a coordinate system x^1, \dots, x^n in the neighbourhood V of x_0 such that v has the form

$$\begin{aligned}\dot{x}^1 &= \lambda x^1 + f(x) \\ &\dots,\end{aligned}$$

where $f(x) = o(\|x\|)$.

Let $K = \{x \in V : x^1 > 0, \|x\| < \varepsilon, |x^i| < x^1 \text{ for all } i > 1\}$, where $\varepsilon > 0$.

Obviously, the intersection of K with any open neighbourhood of x_0 has non-empty interior. We claim that for sufficiently small ε there exists $\delta > 0$ such that all trajectories starting at K leave $U_\delta(x_0)$. Indeed, let

$$M = \sup_{x \in K} \frac{|f(x)|}{\|x\|}.$$

Then $\dot{x}_1 > \lambda x^1 - M\sqrt{n}x^1 = (\lambda - M\sqrt{n})x^1$.

If ε is small, then M is also small and x^1 will have exponential growth, q.e.d.

The case of a complex eigenvalue is analogous. □

Corollary 6.18.1. *Let $v = \text{sgrad } H$ be a non-resonant integrable Hamiltonian system and x be an equilibrium point of it. Suppose that there exists an integral f such that $\text{sgrad } f(x) = 0$ and the linearization of $\text{sgrad } f$ at x has an eigenvalue with non-zero real part. Then x is an unstable equilibrium for $\text{sgrad } H$.*

Proof. Since the linearization of $\text{sgrad } f$ at x has an eigenvalue with non-zero real part, it has an eigenvalue with positive real part. Therefore, we

can find a set K from the lemma. For any ε the intersection $U_\varepsilon(x) \cap K$ has non-empty interior. Therefore, we can find a non-resonant torus passing through $U_\varepsilon(x) \cap K$. The trajectory of $\text{sgrad } f$ lies on this torus, therefore this torus will leave $U_\delta(x)$. But since the torus is non-resonant, all trajectories of $\text{sgrad } H$ are dense on it and will leave $U_\delta(x)$ as well. Therefore, x is an unstable equilibrium, q.e.d. \square

Proof of Theorem 13. By Proposition 4.2.3 the following sets of operators are equal

$$\{D_f P_\alpha |_{\text{Ker } P_\lambda}, f \in \mathcal{F}, df \in \text{Ker } P_\alpha\} = \{\text{ad}_\xi, \xi \in \mathfrak{g}_\lambda \cap L\},$$

where ad_ξ is the adjoint operator in \mathfrak{g}_λ .

Conditions of the theorem imply that for some λ there is $\xi \in \mathfrak{g}_\lambda \cap L$ such that the operator ad_ξ has an eigenvalue with non-zero real part (see the formulas for the eigenvalues given by Propositions 6.15.2, 6.15.3). Therefore, there exists an integral f such that $D_f P_\alpha$ also has such an eigenvalue. But $D_f P_\alpha$ is dual to the linearization of $\text{sgrad } f$. Now it suffices to apply corollary 6.18.1. \square

Now we shall prove that all exotic equilibria are unstable.

Proposition 6.18.1. *Let M be an exotic equilibrium. Then there exists λ such that $\text{sgrad } H_\lambda \neq 0$, where*

$$H_\lambda = -\frac{1}{2} \langle (J + \sqrt{\lambda}E)^{-1} \Omega (J + \sqrt{\lambda}E)^{-1}, M \rangle.$$

Proof. The vector field $\text{sgrad } H_\lambda$ has the form

$$\dot{M} = [(J + \nu E)^{-1} \Omega (J + \nu E)^{-1}, M],$$

where $\nu = \sqrt{\lambda}$.

Suppose that M is an equilibrium point for $\text{sgrad } H_\lambda$ for all λ . Then

$$\begin{aligned} 0 &= [(J + \nu E)^{-1}\Omega(J + \nu E)^{-1}, J\Omega + \Omega J] = \\ &= (J + \nu E)^{-1}\Omega^2 + (J + \nu E)^{-1}\Omega(J + \nu E)^{-1}\Omega(J - \nu E) - \\ &\quad - (J - \nu E)\Omega(J + \nu E)^{-1}\Omega(J + \nu E)^{-1} - \Omega^2(J + \nu E)^{-1}. \end{aligned}$$

Since M is an equilibrium point of the body, Ω^2 commutes with J . Therefore, it also commutes with $(J + \nu E)^{-1}$. Consequently,

$$\begin{aligned} (J + \nu E)^{-1}\Omega(J + \nu E)^{-1}\Omega(J - \nu E) &= \\ &= (J - \nu E)\Omega(J + \nu E)^{-1}\Omega(J + \nu E)^{-1}. \end{aligned}$$

But this equality means that the matrix

$$(J + \nu E)^{-1}\Omega(J + \nu E)^{-1}\Omega(J - \nu E)$$

is symmetric. Let us denote by ω_{ij} the entries of the matrix Ω . λ_i are, as usual, diagonal entries of J . Then the symmetry condition can be written as:

$$\frac{\lambda_k - \nu}{\lambda_i + \nu} \sum_j \frac{\omega_{ij}\omega_{jk}}{\lambda_j + \nu} = \frac{\lambda_i - \nu}{\lambda_k + \nu} \sum_j \frac{\omega_{ij}\omega_{jk}}{\lambda_j + \nu}$$

for all i, k .

Since all eigenvalues of J are distinct, this implies

$$\sum_j \frac{\omega_{ij}\omega_{jk}}{\lambda_j + \nu} = 0$$

for all $i \neq k$.

This equation should be satisfied for all ν . But this means that

$$\omega_{ij}\omega_{jk} = 0$$

for all j and all distinct i, k . Therefore, we can bring Ω to the block-diagonal form with two-by-two blocks on the diagonal by permuting basis vectors.

Such a permutation will preserve diagonal form of J . Consequently, M is not exotic, but regular. Contradiction. \square

Proof of Theorem 14. By the previous Proposition we can find an integral f such that $\text{sgrad } f(M) \neq 0$ for a given exotic equilibrium M . Obviously, the trajectories of $\text{sgrad } f$ leave sufficiently small neighbourhood of M . Therefore, Liouville tori leave this neighbourhood as well. Since our system is non-resonant, it's trajectories are dense on most Liouville tori and will also leave the neighbourhood, q.e.d. \square

Remark 6.18.1. We used Proposition 6.18.1 to show that exotic equilibria are not rank zero singular points. For equilibria not belonging to the set Bad this follows automatically from Theorem 16.

Remark 6.18.2. Since $\text{sgrad } H_\lambda(M) \neq 0$ for any exotic equilibrium M and some value λ , exotic equilibria are not isolated on the symplectic leaves of the $\mathfrak{so}(n)$ -bracket, but form smooth families. The dimension of such a family essentially depends on the sizes of the blocks A_i , entering formula (6.2).

Bibliography

- [1] V. I. Arnold. Conditions for Nonlinear Stability of the Stationary Plane Curvilinear Flows of an Ideal Fluid. *Doklady Matematicheskikh Nauk*, 162(5):773–777, 1965.
- [2] V.I. Arnold. *Mathematical Methods of Classical Mechanics*. Springer-Verlag, 1978.
- [3] P. Birtea and I. Caşu. Energy methods in the stability problem for the $\mathfrak{so}(4)$ free rigid body. *arXiv:1010.0295v2*, 2011.
- [4] P. Birtea, I. Casu, T. Ratiu, and M. Turhan. Stability of equilibria for the $\mathfrak{so}(4)$ free rigid body. *arXiv:0812.3415*, 2008.
- [5] A. V. Bolsinov. Compatible Poisson brackets on Lie algebras and the completeness of families of functions in involution. *Mathematics of the USSR-Izvestiya*, 38(1):69–90, 1992.
- [6] A. V. Bolsinov and A. V. Borisov. Compatible Poisson brackets on Lie algebras. *Mathematical Notes*, 72:10–30, 2002.
- [7] A.V. Bolsinov and A.T. Fomenko. *Integrable Hamiltonian systems. Geometry, Topology and Classification*. CRC Press, 2004.

- [8] A.V. Bolsinov and A.A. Oshemkov. Bi-Hamiltonian structures and singularities of integrable systems. *Regular and Chaotic Dynamics*, 14:431–454, 2009.
- [9] I. Caşu. On the stability problem for the $\mathfrak{so}(5)$ free rigid body. *arXiv:1009.2387v2*, 2011.
- [10] J.-P. Dufour and Nguyen Tien Zung. *Poisson Structures and Their Normal Forms (Progress in Mathematics)*. Birkhauser Basel, 2005.
- [11] L. Eliasson. *Normal forms for Hamiltonian systems with Poisson commuting integrals*. PhD thesis, University of Stockholm, 1984.
- [12] L. Eliasson. Normal forms for Hamiltonian systems with Poisson commuting integrals - elliptic case. *Commentarii Mathematici Helvetici*, 65:4–35, 1990.
- [13] Yu.N. Fedorov. Integrable systems, Poisson pencils, and hyperelliptic Lax pairs. *Journal of Mathematical Sciences*, 94:1501–1511, 1999.
- [14] L. Fehér and I. Marshall. Stability analysis of some integrable Euler equations for $SO(n)$. *J. Nonlinear Math. Phys.*, 10(3):304–317, 2003.
- [15] A.T. Fomenko. Morse theory of integrable Hamiltonian systems. *Sov. Math., Dokl.*, 33:502–506, 1986.
- [16] A.T. Fomenko. The topology of surfaces of constant energy in integrable Hamiltonian systems, and obstructions to integrability. *Mathematics of the USSR-Izvestiya*, 29(3):629, 1987.
- [17] I. M. Gel'fand and I. Ya. Dorfman. Hamiltonian operators and algebraic structures related to them. *Functional Analysis and Its Applications*, 13:248–262, 1979.

- [18] M.P. Kharlamov and T.I. Pogosian. Bifurcation set and integral manifolds of the problem concerning the motion of a rigid body in a linear force field. *Journal of Applied Mathematics and Mechanics*, 43(3):452 – 462, 1979.
- [19] A.A. Kirillov. *Lectures on the orbit method*. American Mathematical Society, Providence, 2004.
- [20] L. M. Lerman and Ya. L. Umanskij. Structure of the Poisson action of \mathbb{R}^2 on a four-dimensional symplectic manifold. I. *Selecta Math. Soviet.*, 6(4):365–396, 1987. Selected translations.
- [21] L. M. Lerman and Ya. L. Umanskij. The structure of the Poisson action of \mathbb{R}^2 on a four-dimensional symplectic manifold. II. *Selecta Math. Soviet.*, 7(1):39–48, 1988.
- [22] L.M. Lerman and Ya.L. Umanskij. Classification of four-dimensional integrable Hamiltonian systems and Poisson actions of \mathbb{R}^2 in extended neighbourhoods of simple singular points. I. *Russian academy of sciences, Sbornik mathematics*, 77(2):511–542, 1994.
- [23] L.M. Lerman and Ya.L. Umanskij. Classification of four-dimensional integrable Hamiltonian systems and Poisson actions of \mathbb{R}^2 in extended neighbourhoods of simple singular points. II. *Russian academy of sciences, Sbornik mathematics*, 78(2):479–506, 1994.
- [24] L.M. Lerman and Ya.L. Umanskij. Classification of four-dimensional integrable Hamiltonian systems and Poisson actions of \mathbb{R}^2 in extended neighbourhoods of simple singular points. III. Realization. *Sbornik: mathematics*, 186(10):1477–1491, 1995.

- [25] F. Magri. A simple model of the integrable Hamiltonian equation. *J. Math. Phys.*, 19(5):1156–1162, 1978.
- [26] F. Magri and C. Morosi. *A geometrical characterization of integrable Hamiltonian systems through the theory of Poisson-Nijenhuis manifolds*. University of Milano, 1984.
- [27] S. V. Manakov. Note on the integration of Euler’s equations of the dynamics of an n-dimensional rigid body. *Functional Analysis and Its Applications*, 10:328–329, 1976.
- [28] E. Miranda. *On symplectic linearization of singular Lagrangian foliations*. PhD thesis, Universitat de Barcelona, 2003.
- [29] A. S. Mishchenko. Integral geodesics of a flow on Lie groups. *Functional Analysis and Its Applications*, 4:232–235, 1970.
- [30] A.S. Mishchenko and A.T. Fomenko. Euler equations on finite-dimensional Lie groups. *Mathematics of the USSR-Izvestiya*, 12(2):371–389, 1978.
- [31] C. Morosi and L. Pizzocchero. On the Euler equation: Bi-Hamiltonian structure and integrals in involution. *Letters in Mathematical Physics*, 37:117–135, 1996.
- [32] A.A. Oshemkov. The topology of surfaces of constant energy and bifurcation diagrams for integrable cases of the dynamics of a rigid body on $\mathfrak{so}(4)$. *Russ. Math. Surv.*, 42(6):241–242, 1987.
- [33] A. Panasyuk. Bi-Hamiltonian structures with symmetries, Lie pencils and integrable systems. *J. Phys. A*, 42(16):165205, 20, 2009.

- [34] G.W. Patrick, M. Roberts, and C. Wulff. Stability of Poisson equilibria and Hamiltonian relative equilibria by energy methods. *Archive for Rational Mechanics and Analysis*, 174:301–344, 2004.
- [35] T. Ratiu. The motion of the free n -dimensional rigid body. *Indiana Univ. Math. J.*, 29:609–629, 1980.
- [36] A. G. Reiman and M. A. Semenov-Tyan-Shanskii. A family of Hamiltonian structures, hierarchy of hamiltonians, and reduction for first-order matrix differential operators. *Functional Analysis and Its Applications*, 14:146–148, 1980.
- [37] A. Spiegler. *Stability of generic equilibria of the $2N$ dimensional free rigid body using the energy-Casimir method*. PhD thesis, University of Arizona, 2006.
- [38] R. Thompson. Pencils of complex and real symmetric and skew matrices. *Linear Algebra and its Applications*, 147(0):323 – 371, 1991.
- [39] J. Williamson. On the algebraic problem concerning the normal forms of linear dynamical systems. *American Journal of Mathematics*, 58(1):141–163, 1936.
- [40] I. Zakharevich. Kronecker webs, bihamiltonian structures, and the method of argument translation. *Transformation Groups*, 6:267–300, 2001.